

# Chemistry 4631

## Instrumental Analysis

### Lecture 15



# IR Spectroscopy

## Infrared Spectroscopy

**FTIR is Fourier-Transform Infrared Spectroscopy**

**It is a chemically specific technique – used to identify chemical compounds and functional groups.**

# IR Spectroscopy

## Infrared Spectroscopy

IR radiation occurs between 0.7 and 1000  $\mu\text{m}$ .

TABLE 16-1 IR Spectral Regions

Region	Wavelengths ( $\lambda$ ), $\mu\text{m}$	Wavenumbers ( $\bar{\nu}$ ), $\text{cm}^{-1}$	Frequencies ( $\nu$ ), Hz
Near	0.78 to 2.5	12800 to 4000	$3.8 \times 10^{14}$ to $1.2 \times 10^{14}$
Middle	2.5 to 50	4000 to 200	$1.2 \times 10^{14}$ to $6.0 \times 10^{12}$
Far	50 to 1000	200 to 10	$6.0 \times 10^{12}$ to $3.0 \times 10^{11}$
Most used	2.5 to 15	4000 to 670	$1.2 \times 10^{14}$ to $2.0 \times 10^{13}$

© 2007 Thomson Higher Education

Wavelength is measured in "wavenumbers", which have the units  $\text{cm}^{-1}$ .

wavenumber = 1 / wavelength in centimeters

# IR Spectroscopy

## Infrared Spectroscopy

**IR radiation does not have enough energy to induce electronic transitions as seen with UV.**

**IR is an absorption technique which measures vibrations of molecules.**

**Absorption only occurs when the photon interacts with a molecule undergoing a change in dipole.**

# IR Spectroscopy

Molecular vibrations fall into 2 main categories

- **Stretching**
- **Bending**

Stretching vibrations

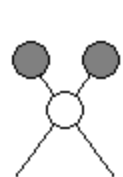

Symmetric

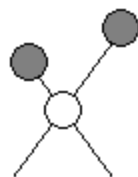

Asymmetric

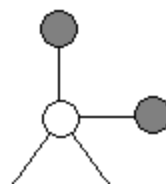

In-plane rocking

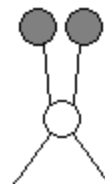

In-plane scissoring

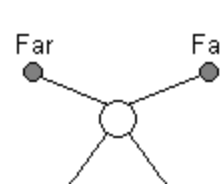

Out-of-plane wagging

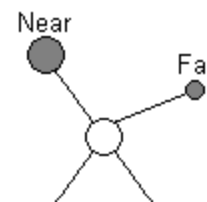

Out-of-plane twisting

Bending vibrations

# IR Spectroscopy

## Typical IR spectrum

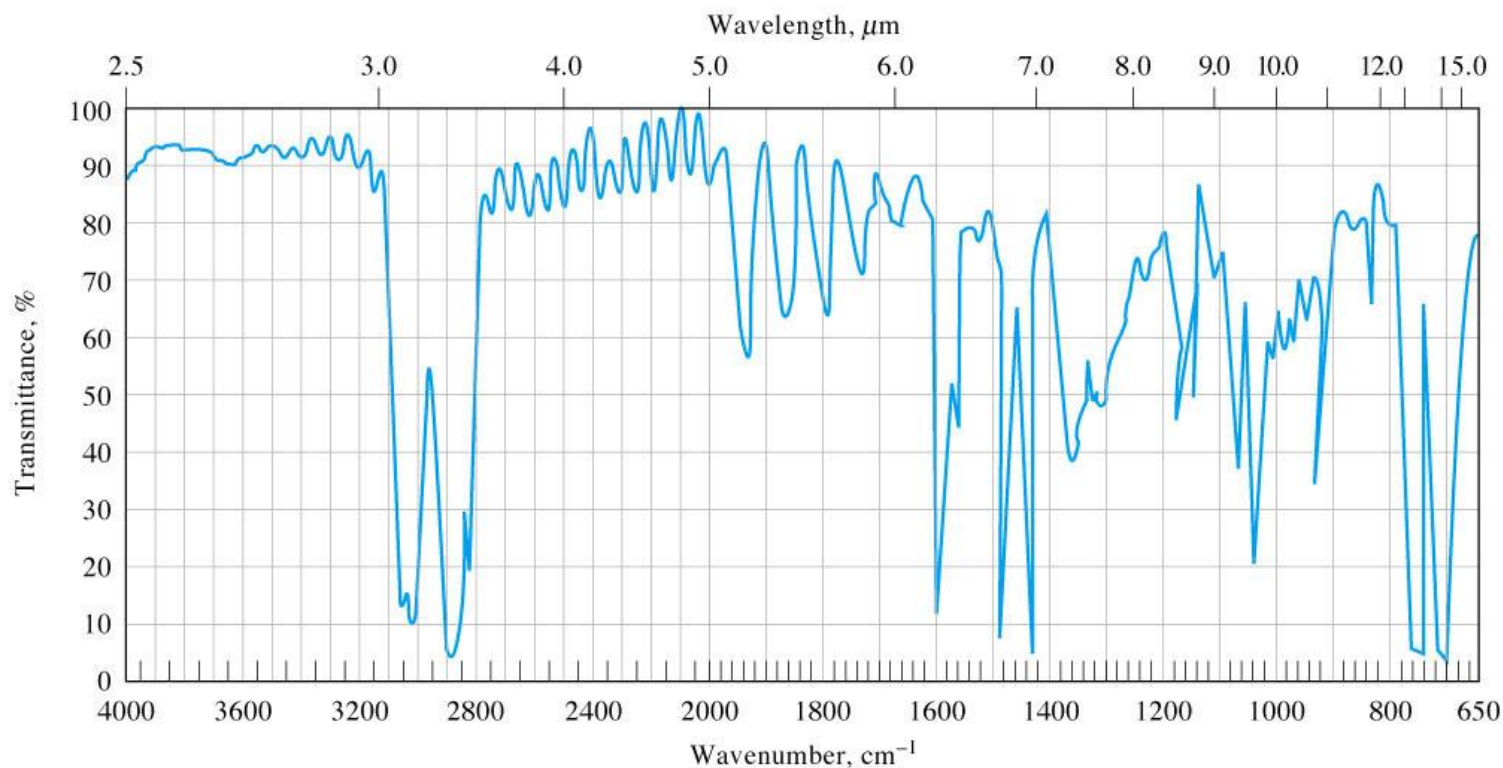

© 2007 Thomson Higher Education

# Components of Optical Instruments

## Instrument IR Sources

Inert solid heated electrically to a temperature between 1500-2200 K, to give continuum radiation.

## Nernst Glower

Composed of rare earth oxides in the shape of a cylinder (diameter – 1 to 2 mm, length – 20 mm). Platinum leads connected to ends of cylinder.

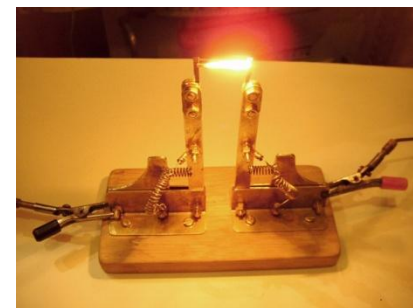
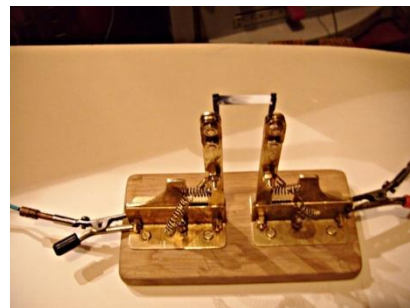

# Components of Optical Instruments

## IR Sources

### Global Source

A SiC rod (diameter – 5 mm, length – 50 mm) that has a positive coefficient of resistance. Contacts must be water cooled to prevent arcing.



# Components of Optical Instruments

## IR Sources

### Incandescent wire source

Spiral of nichrome wire heated to about 1100K.  
Intensity lower but longer life.

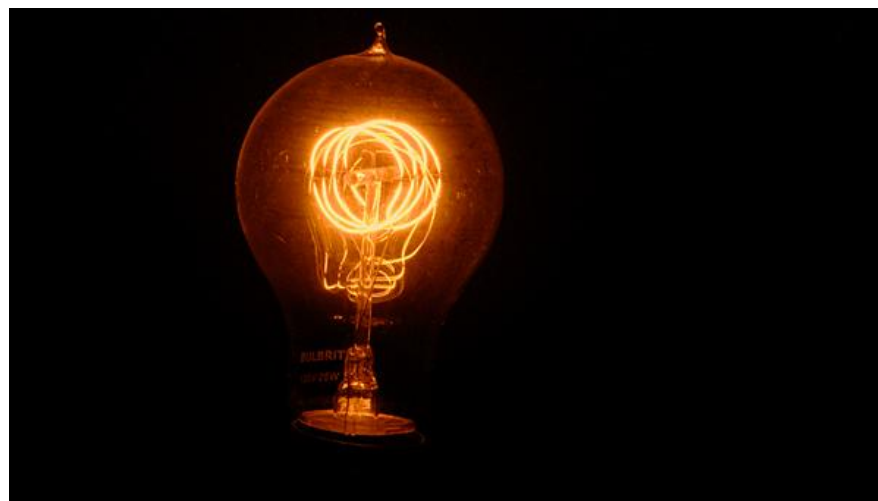

# Components of Optical Instruments

## IR Sources

### Mercury Arc

Quartz-jacketed tube containing mercury vapor.

Electrical current passed through vapor to give radiation in far-infrared region ( $\lambda > 50 \mu\text{m}$ ).

# Components of Optical Instruments

## IR Sources

### Carbon Dioxide Laser Source

Tunable laser produces band of radiation in 900-1100  $\text{cm}^{-1}$  range. This region is sensitive for  $\text{CO}_2$  stretching and for determination of ammonia, benzene, ethanol,  $\text{NO}_2$ , etc...

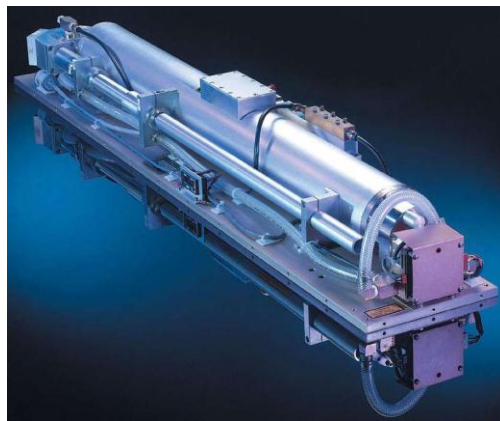
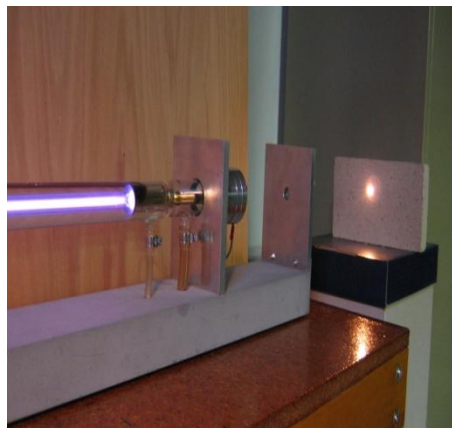

# Components of Optical Instruments

## Instrument Transducers

For measurement in IR region

Three general types:

- Thermal
- Pyroelectric
- Photoconductivity

# Components of Optical Instruments

## Transducers

### Thermal Transducers

Radiation is absorbed by a small blackbody and the temperature rise is measured. Radiant power from the beam is  $10^{-7}$  to  $10^{-9}$  W, so heat capacity of absorbing element must be small.

Temperature changes are  $\sim 0.001$  Kelvin.

# Components of Optical Instruments

## Transducers

### Thermal Transducers

#### Thermal noise is biggest drawback

- So detector is housed in a vacuum and shielded from stray radiation.
- Source beam is chopped so signal has same frequency as the chopper.

# Components of Optical Instruments

## Transducers

### Thermal Transducers

#### Thermocouples

A pair of junctions formed from two pieces of metal.

Example: bismuth pressed to end of a dissimilar metal like antimony.  
The two metals heat to different temperatures and a potential develops.

Responds to temperature differences of  $10^{-6}$  K.

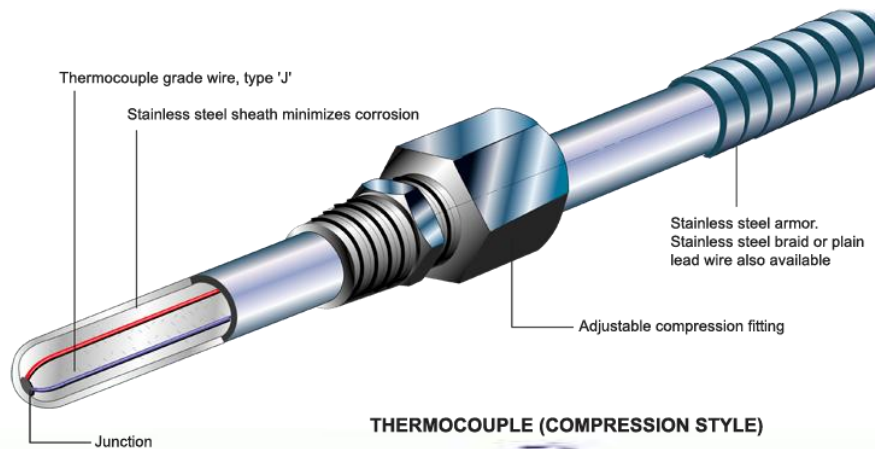

# Components of Optical Instruments

## Transducers

### Thermal Transducers

#### Bolometers

- Types of resistance thermometer made from strips of metal (i.e. Pt or Ni) or strips of semiconductor (thermistors).
- Material has large change in resistance with temperature.
- Used in specialized applications from 5 to 400  $\text{cm}^{-1}$  (2000 to 25  $\mu\text{m}$ ).

# Components of Optical Instruments

## Transducers

### Pyroelectric Transducers

Made from a single crystalline wafer of pyroelectric material that is an insulator (dielectric) such as triglycine sulfate  $(\text{NH}_2\text{CH}_2\text{COOH})_3 \text{H}_2\text{SO}_4$

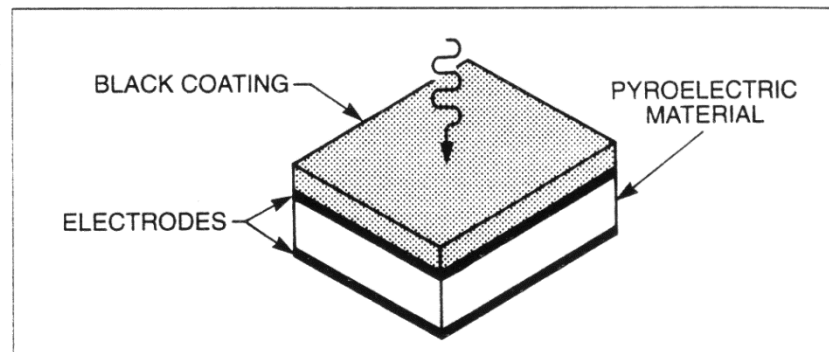

Fig. 6 Schematic of a pyroelectric detector.



# Components of Optical Instruments

## Transducers

### Pyroelectric Transducers

- An electric field is applied across the material causing an electric polarization.
- The induced polarization is temperature dependent and measured by metal electrodes.

# Components of Optical Instruments

## Transducers

### Photoconducting Transducers

Thin films of a semiconducting material , i.e. lead sulfide, Hg/Cd Te, or In/Sb is deposited on a nonconducting surface and sealed in an evacuated envelope.

# Components of Optical Instruments

## Transducers

### Photoconducting Transducers

Absorption of radiation by the film promotes electrons from the valence to conducting band decreasing the electrical resistance of the semiconductor.

Lead sulfide most widely used for near IR region (10,000 to 333  $\text{cm}^{-1}$ ). For mid and far IR use Hg/Cd Te.

# Components of Optical Instruments

## Instrument

## Sample Cells – for solvents

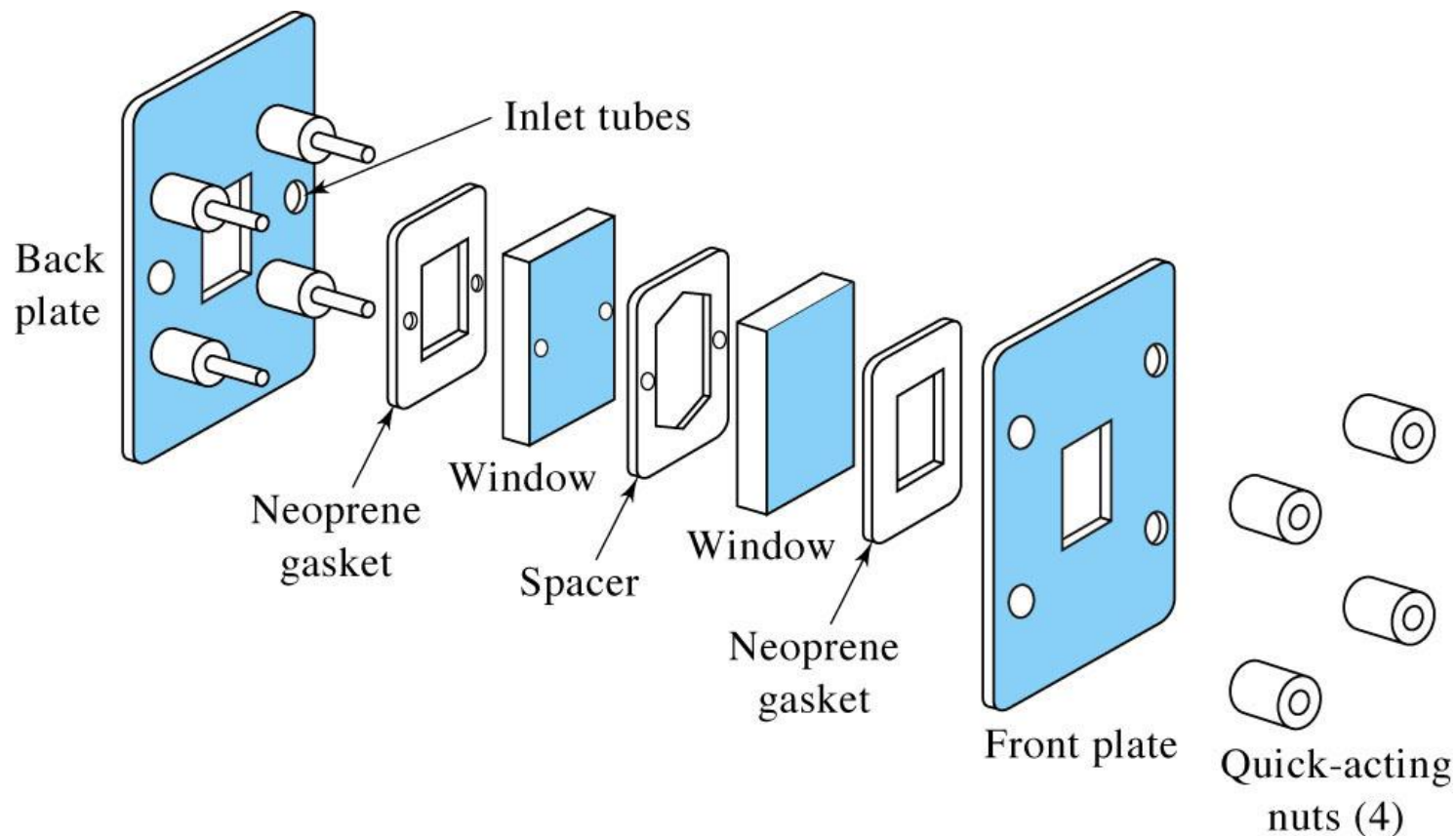

© 2007 Thomson Higher Education

# Components of Optical Instruments

**Solvents – no single solvent is transparent throughout the mid-IR region**

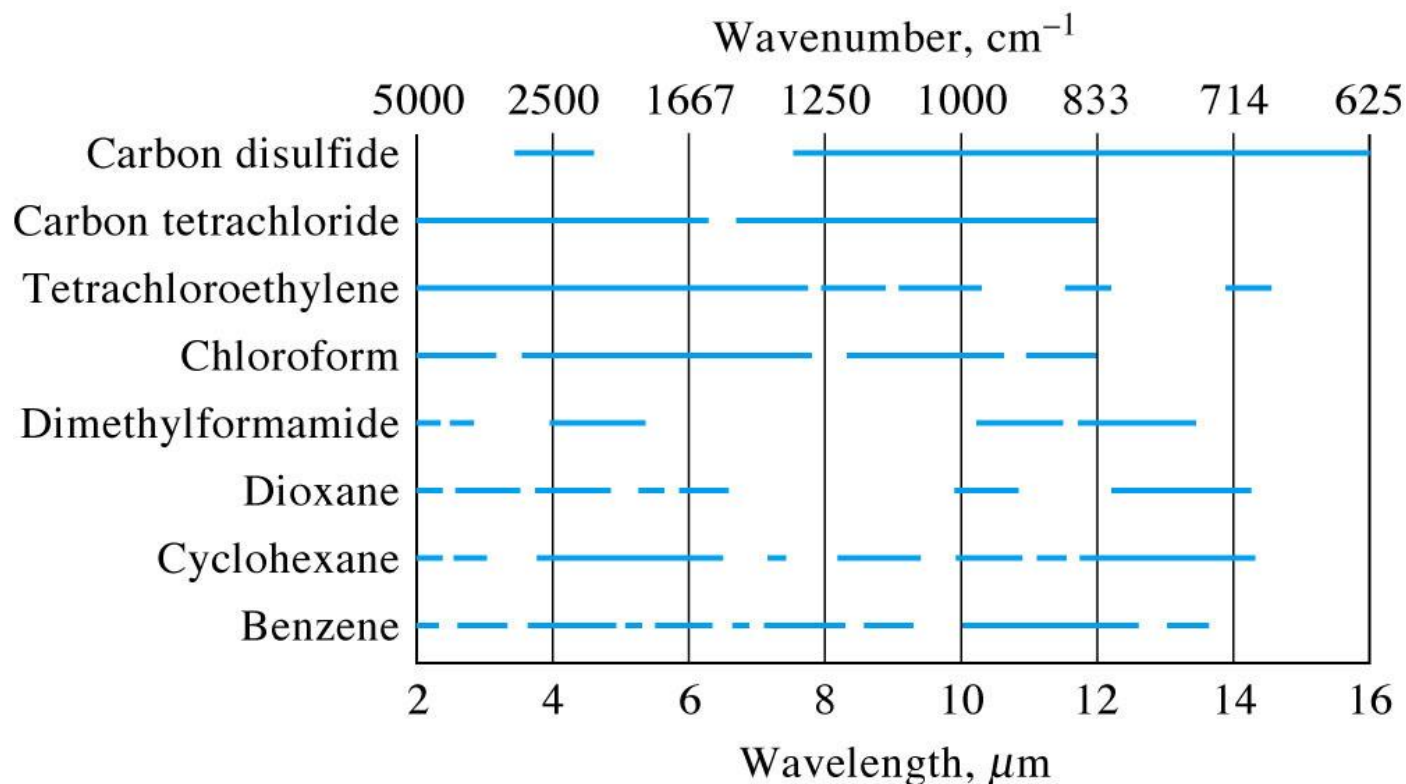

© 2007 Thomson Higher Education

# Components of Optical Instruments

## Cells

## Solids

- Must grind into a powder
- Most common method for solids is placing in KBr pellets
- The solid (1 mg) is mixed with KBr powder (100 mg)
- The mixture is pressed in a special die at 10,000-15,000 lbs/in<sup>2</sup>
- Method gives excellent spectrum
- Thin film solids done by reflectance

# Components of Optical Instruments

## Cells Solids

**TABLE 17-2** Common IR Window Materials

Window Material	Applicable Range, $\text{cm}^{-1}$	Water Solubility, $\text{g}/100 \text{ g H}_2\text{O}$ , $20^\circ\text{C}$
Sodium chloride	40,000–625	36.0
Potassium bromide	40,000–385	65.2
Potassium chloride	40,000–500	34.7
Cesium iodide	40,000–200	160.0
Fused silica	50,000–2,500	Insoluble
Calcium fluoride	50,000–1,100	$1.51 \times 10^{-3}$
Barium fluoride	50,000–770	0.12 ( $25^\circ\text{C}$ )
Thallium bromide-iodide, KRS-5	16,600–250	<0.0476
Silver bromide	20,000–285	$1.2 \times 10^{-7}$
Zinc sulfide, Irtran-2	10,000–715	Insoluble
Zinc selenide, Irtran-4	10,000–515	Insoluble
Polyethylene	625–30	Insoluble

# IR Instruments

## Types of Instrumentation

- Dispersive Spectrophotometers (gratings)
- Fourier transform spectrometers (interferometer)
  - Single beam
  - Double beam
- Nondispersive photometers (filter or gas)
- Speciality

# IR Instruments

## Infrared Instruments

### Dispersive

Dispersive IR spectrometers are usually double beam devices which use reflection gratings for dispersing radiation.

The double-beam design is less demanding on the performance of the sources and detectors.

Also the reference beam compensates perfectly for the background.

# IR Instruments

## Infrared Instruments

### Dispersive

Instrument incorporates a low-frequency chopper (5-30 cycles per second) to help the detector discriminate between the signal from the source and signals from extraneous radiation.

The instrument design is similar to double-beam UV spectrophotometers except the sample and reference cells are always located between the source and the monochromator.

# IR Instruments

## Infrared Instruments

*Schematic of a dispersive (double beam) IR spectrometer*

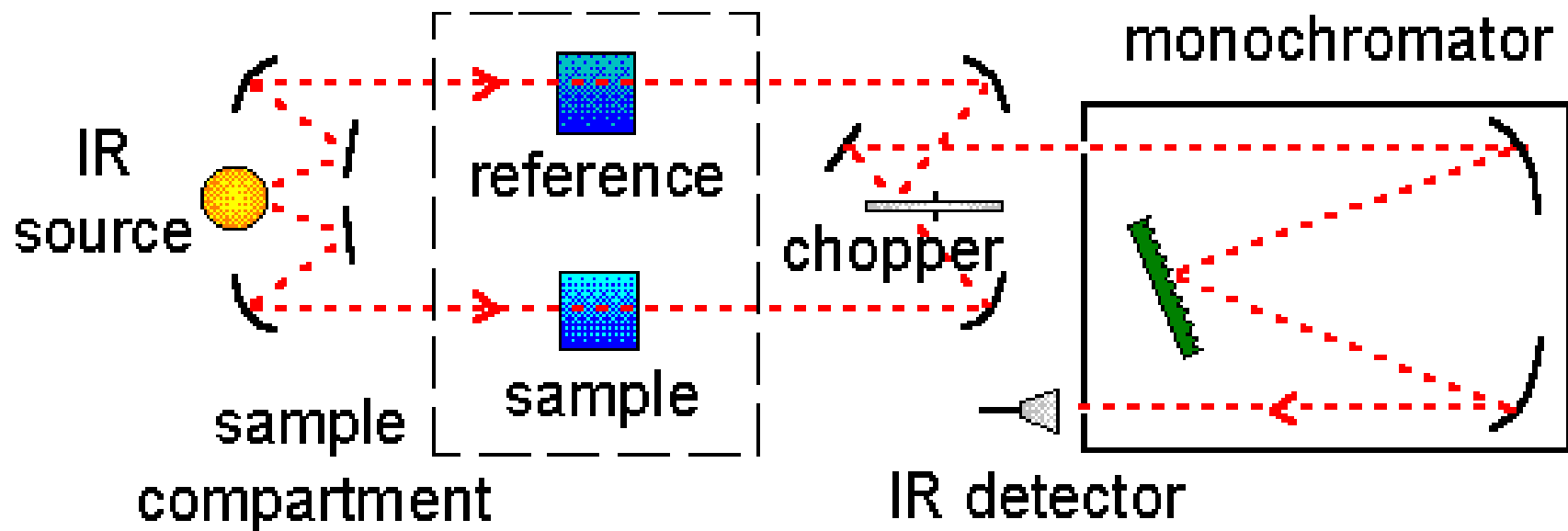

©1995 CHP

# IR Instruments

## Infrared Instruments

### Dispersive

Dispersive IR spectrometers have largely been replaced with FTIR instruments. They find use in specific research applications, such as monitoring a single IR wavelength to measure the kinetics of a fast reaction.

# IR Instruments

## Types of Instrumentation

### Nondispersive photometers

Simple, rugged design for use in quantitative IR analysis.

Design may be a simple filter photometer or use filter wedges.

# IR Instruments

## Types of Instrumentation

**Nondispersive photometers - filter photometer**

**Typically used for analysis of gases in the atmosphere.**

**The instrument is pre-calibrated by the manufacturer for 1 to 100 gases.**

**Gases introduced with a battery-powered pump at 20 L/min.**

**Detection limits ppm, portable, simple, less expensive**

# IR Instruments

## Nondispersive photometers

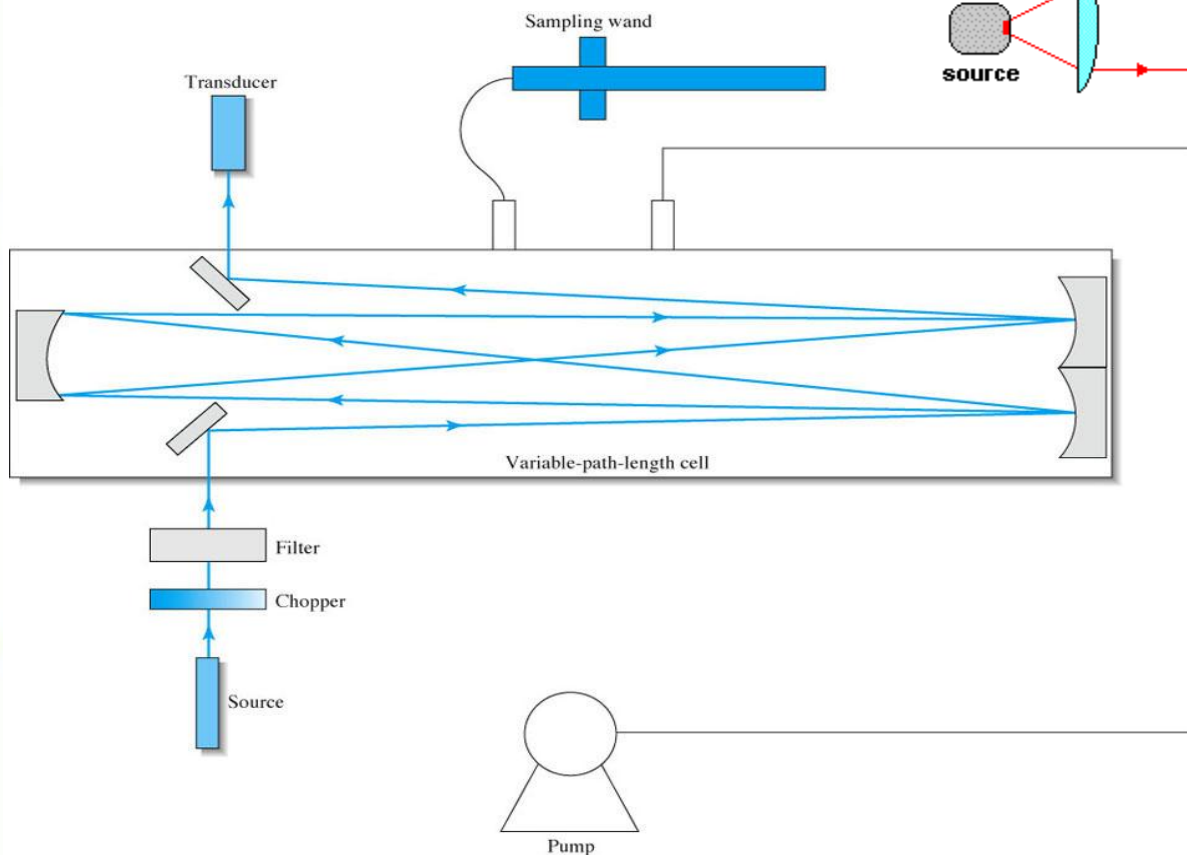

Typical Infrared Photometer

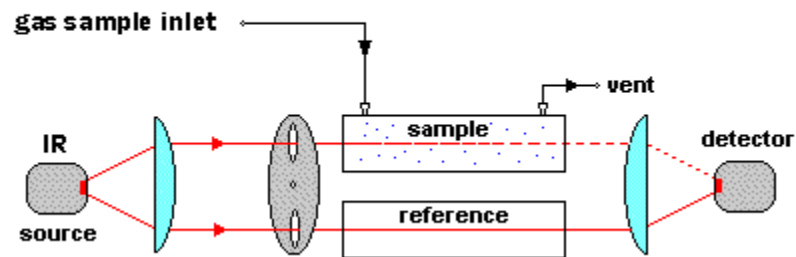

# IR Techniques

## IR Microscopy

**An IR microscope uses two light beams, one visible and the other IR.**

**The beams travel together to the sample. The IR spectrum can be collected in either transmission or reflectance mode.**

**Sampling area can be as small as 10  $\mu\text{m}$ .**

# IR Techniques

## IR Microscopy

**The IR signal from the sample goes to a small MCT detector.**

**MCT detector – HgCdTe semiconductor detector which becomes conducting in response to IR signals**

# IR Techniques

## IR Microscopy

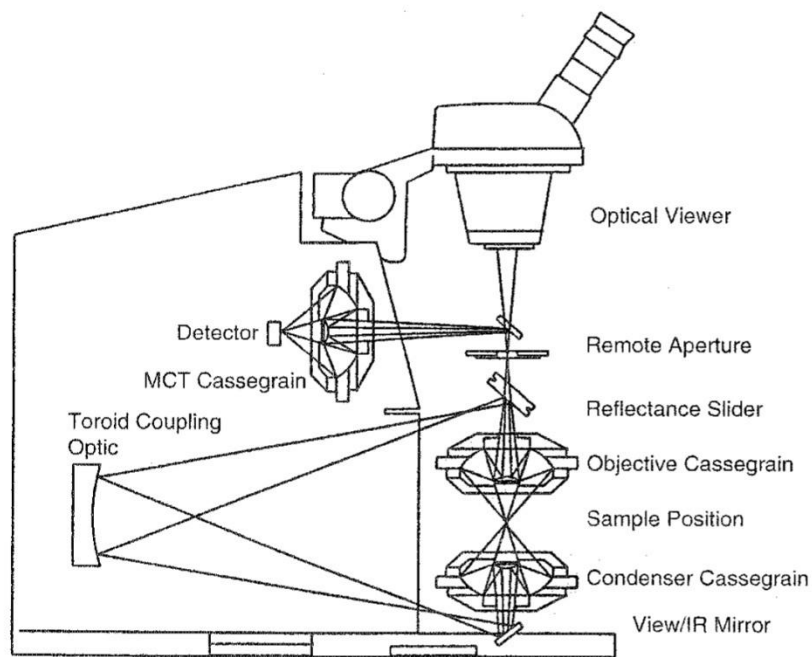

**Figure 4.24** IR microscope schematic with the detector integrated into the microscope. The microscope is usually coupled to a light port on the side of the FTIR spectrometer. The FTIR spectrometer supplies a modulated, collimated beam of light to the microscope. Courtesy of PerkinElmer Instruments, Shelton, CT ([www.perkinelmer.com](http://www.perkinelmer.com)). (From Coates, used with permission.)

# IR Techniques

## IR Microscopy



# IR Techniques

## Applications of FTIR Microspectroscopy

- **Pharmaceuticals**
- **Catalysts**
- **Polymers**
- **Minerals**
- **Artwork**
- **Biological samples**

# Assignment

- Read Chapter 15
- Homework Chapter 15: 1, 2, 4, 5, 9, 13
- HW5 Chapter 15 due 2-20
  
- Read Chapter 16
- Read Chapter 17
  
- HW6 Chapter 16: 7, 8, 11, 12
- HW7 Chapter 17: 2, 4, 5
- HW6 - Due 2-27
- HW7 - Due 2-27
- **Exam II March 4th**

