



Chemistry 4631

Instrumental Analysis

Lecture 18

Introduction to Optical Atomic Spectrometry

From molecular to elemental analysis there are three major techniques used for elemental analysis:

- **Optical spectrometry**
- **Mass spectrometry**
- **X-ray spectrometry**

Introduction to Optical Atomic Spectrometry

History

Father of Modern Atomic Absorption – A. Walsh

(Spectrochem. Acta 7, 108 (1955) (d 1998)

1832 – Brewster – defined 2 lines as absorption of Na in glass

1860's – Bunsen and Kirchoff (Cs and Rb)

1963 – 1st commercial instrument

Introduction to Optical Atomic Spectrometry

For optical spectrometry the sample is converted to gaseous atoms or elementary ions by a process called atomization.

The UV absorbance, emission, or fluorescence of the atomic species is then measured.

Introduction to Optical Atomic Spectrometry

Energy level diagrams for transition metals are very complex and can have thousands of lines in the spectrum.

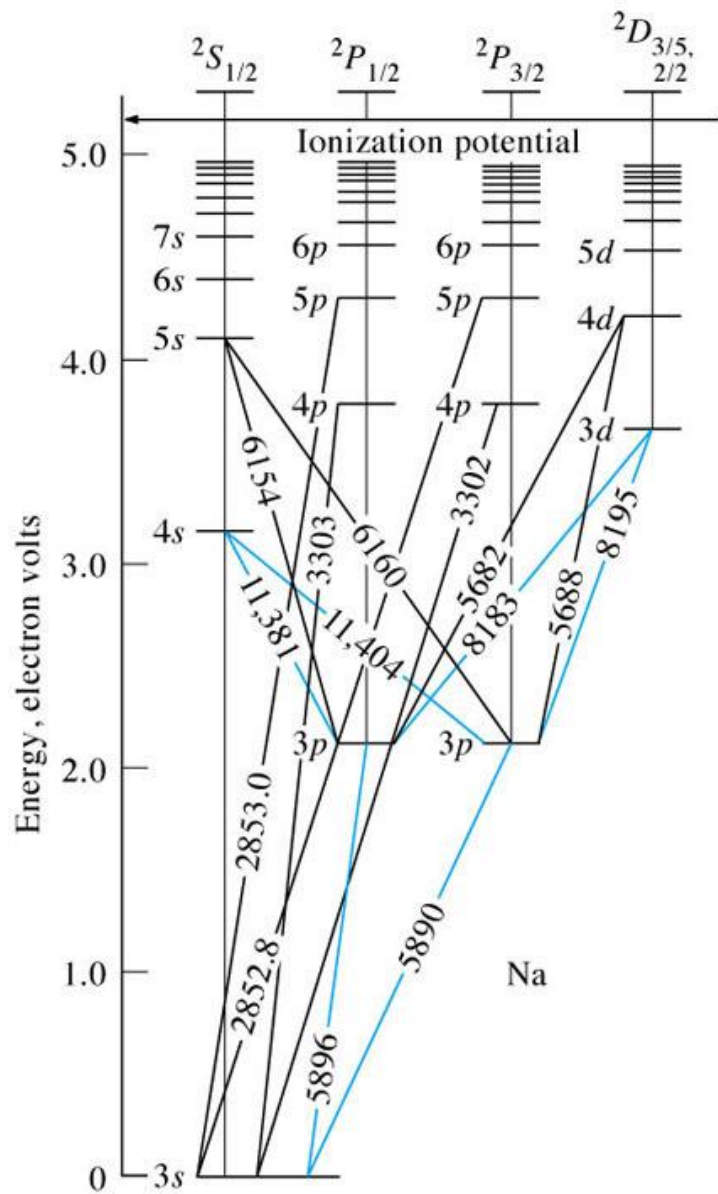

(a)

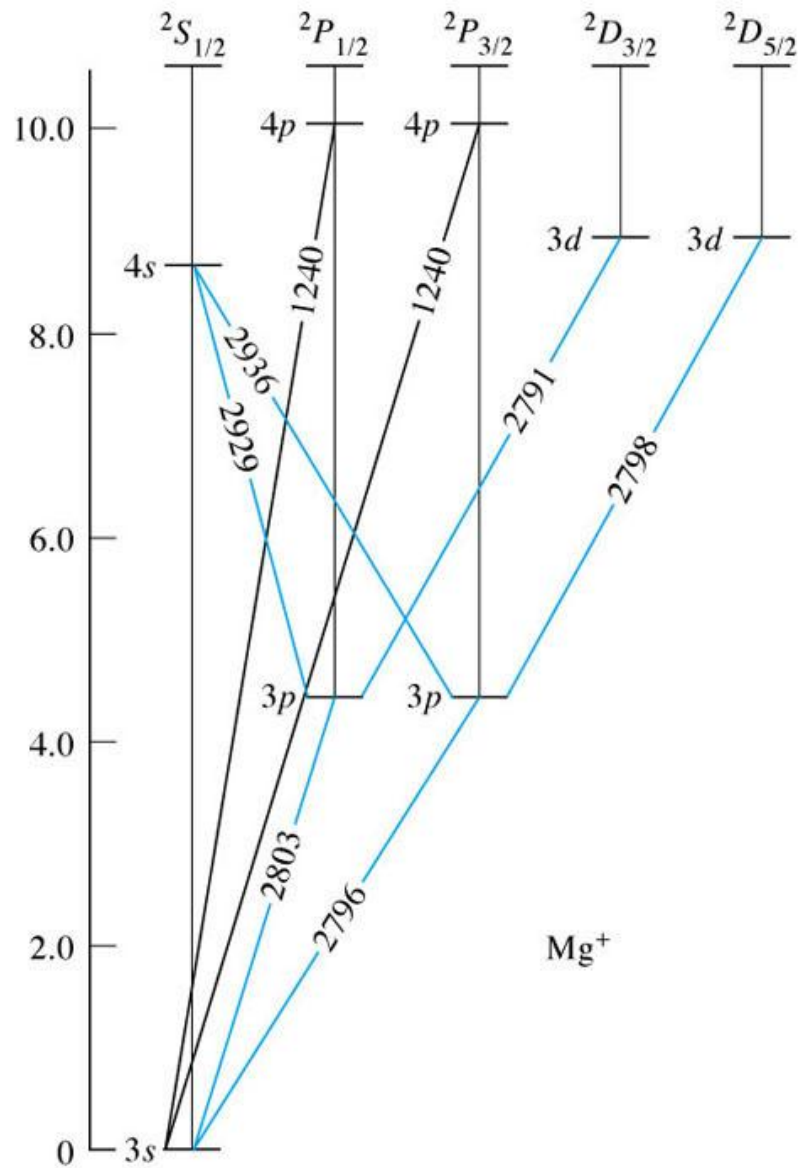

(b)

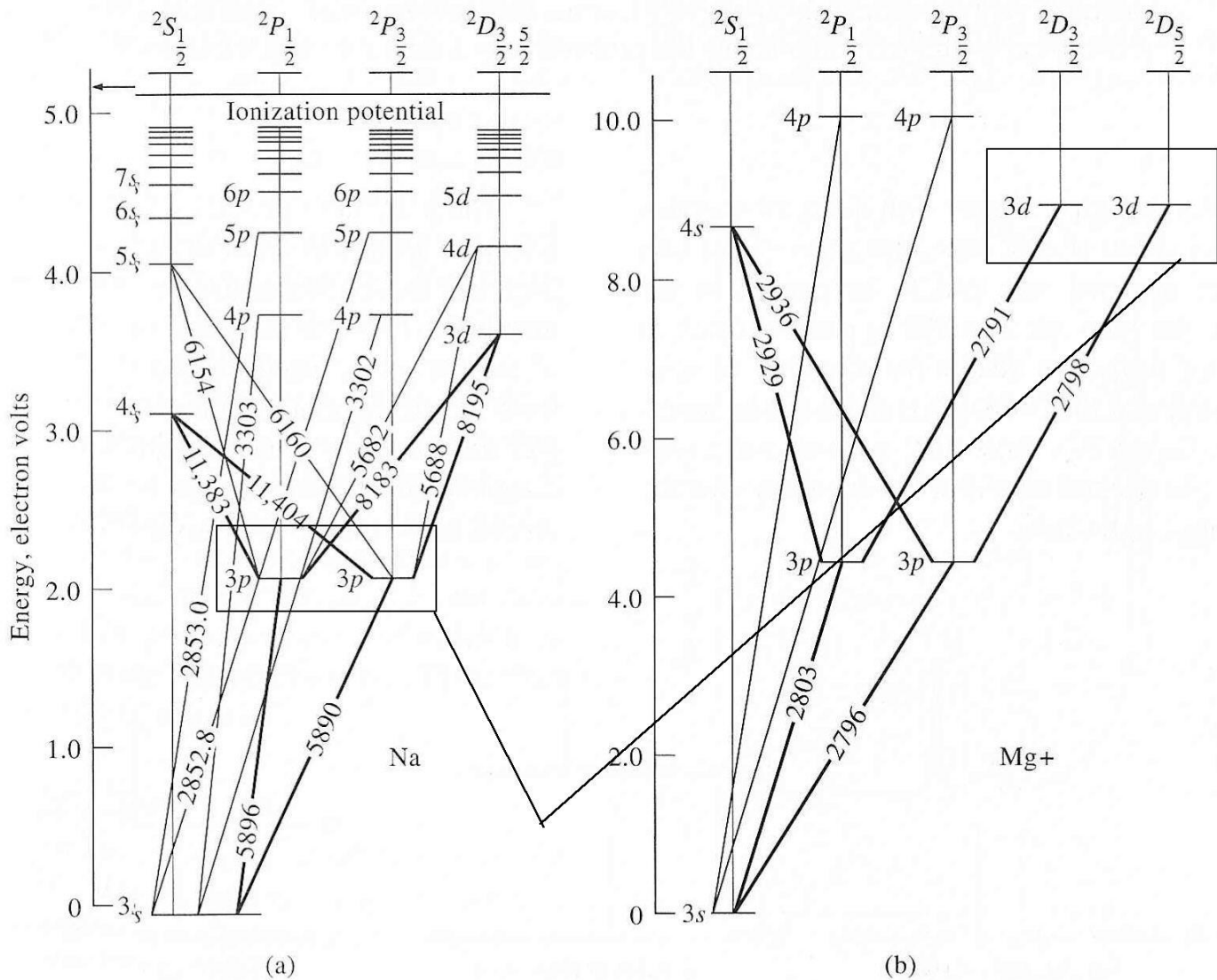

Figure 8-1 Energy level diagrams for (a) atomic sodium and (b) magnesium(I) ion. Note the similarity in pattern of lines but not in actual wavelengths.

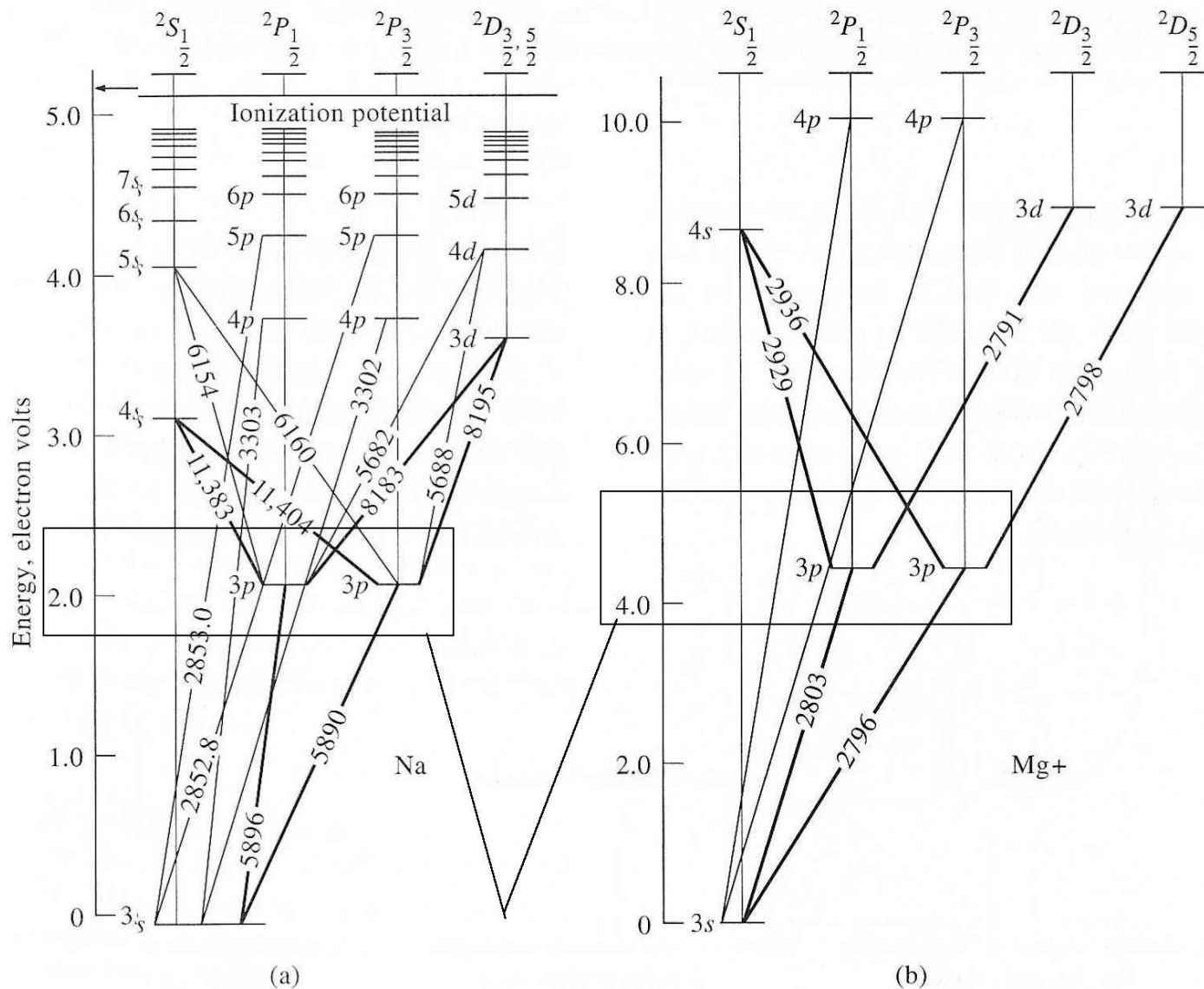

Figure 8-1 Energy level diagrams for (a) atomic sodium and (b) magnesium(I) ion. Note the similarity in pattern of lines but not in actual wavelengths.

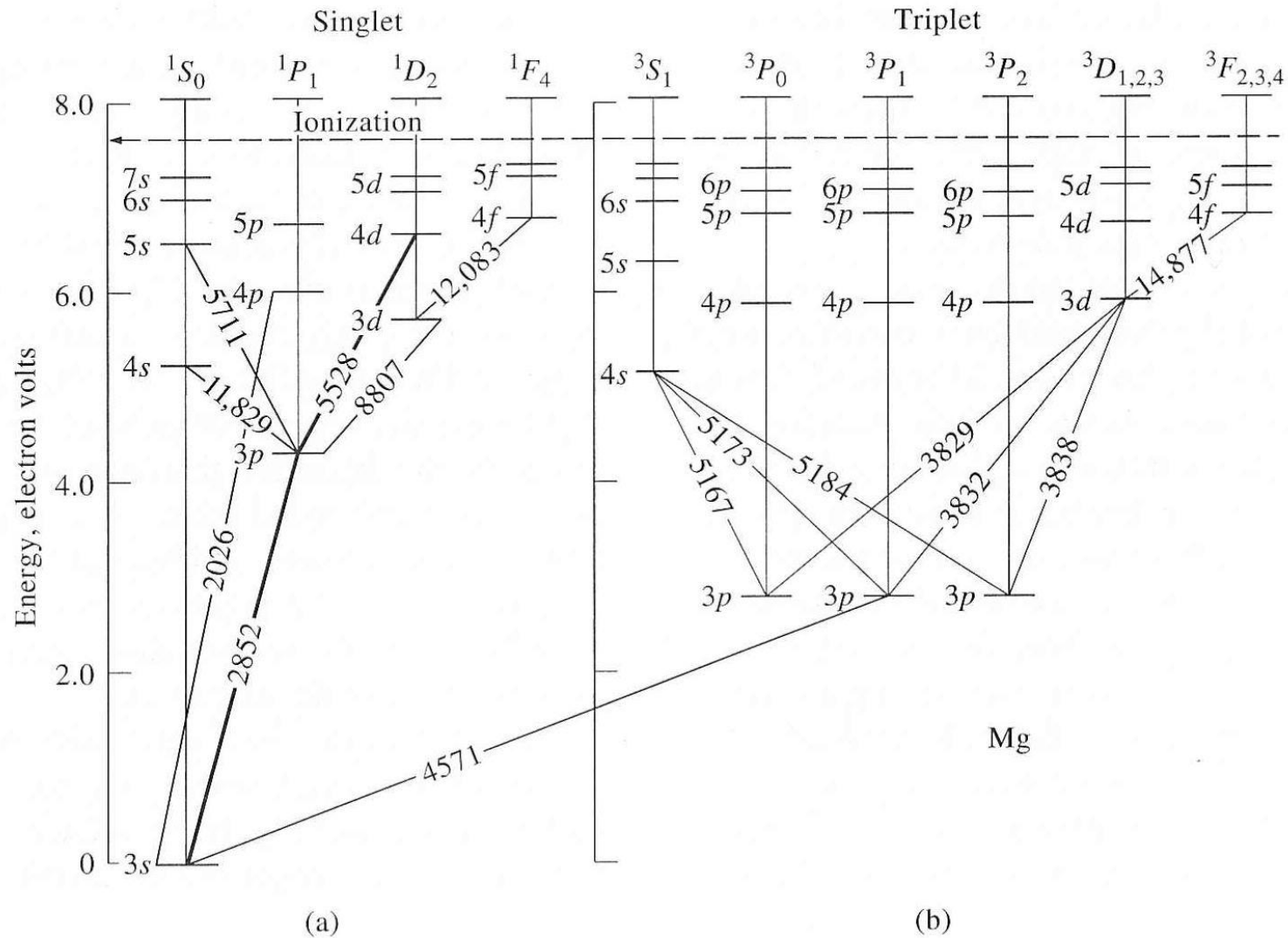

Figure 8-2 Energy level diagram for atomic magnesium. The relative line intensities are indicated very approximately by the width of the lines between states. Note that a singlet/triplet transition is considerably less probable than a singlet to singlet transition.

Introduction to Optical Atomic Spectrometry

Atomic emission spectra

Excitation of an electron to higher orbitals can be brought about by a flame, plasma, or electric arc or spark

Lifetime of excited atom is short and upon return to the ground state there is an emission of a photon.

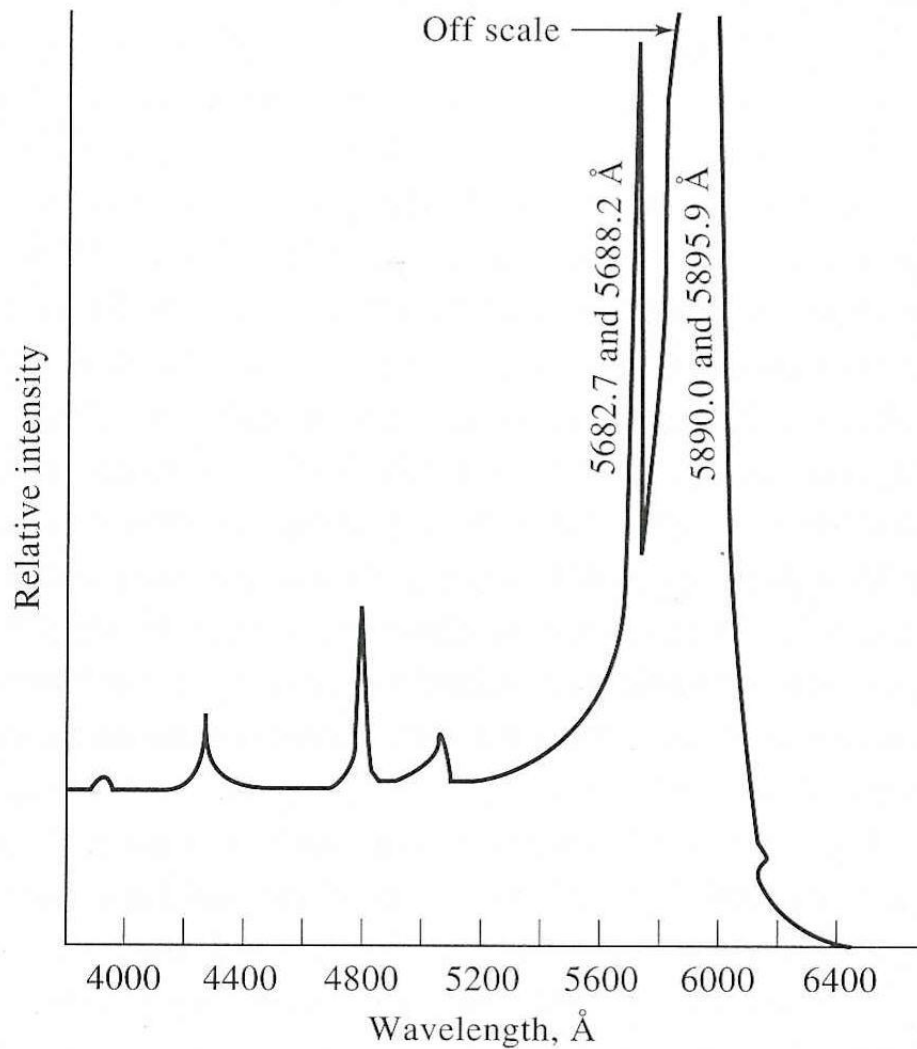

Figure 8-4 A portion of the flame emission spectrum for sodium.

Introduction to Optical Atomic Spectrometry

Atomic Line Widths

Line broadening occurs from:

- The Uncertainty effect
- The Doppler effect
- Pressure effects due to collisions between atoms of the same kind and with foreign atoms
- Electric and magnetic field effects

Introduction to Optical Atomic Spectrometry

Uncertainty effect

Spectral lines have finite widths because the lifetimes of the transition states are finite.

This broadening is called the natural line width and are 10^{-4} Å.

Introduction to Optical Atomic Spectrometry

Doppler Broadening

Wavelength of radiation emitted by moving atoms decreases if the motion is toward a transducer and increases if motion is away from a transducer.
(Doppler shift)

Introduction to Optical Atomic Spectrometry

Doppler Broadening

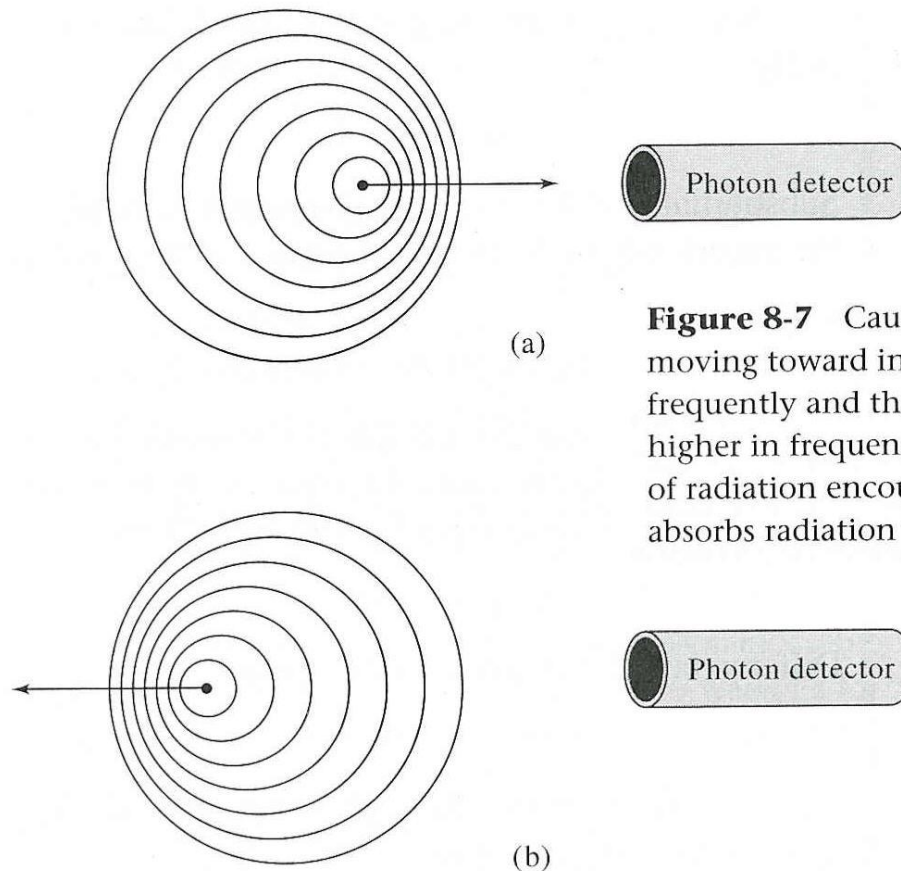

Figure 8-7 Cause of Doppler broadening. (a) Atom moving toward incoming radiation sees wave crests more frequently and thus absorbs radiation that is actually higher in frequency. (b) Atom moving with the direction of radiation encounters wave crests less often and thus absorbs radiation that is actually of lower frequency.

Introduction to Optical Atomic Spectrometry

Doppler Broadening

Magnitude increases with velocity of emitting species.

For atoms in a flame, atomic motion occurs in every direction.

Maximum doppler shifts are for atoms moving directly towards or away from transducers.

Atoms moving perpendicular to the transducer show no shift.

Intermediate shifts are seen depending on atoms speed and direction.

Introduction to Optical Atomic Spectrometry

Doppler Broadening

This variation gives line broadening that is about two orders of magnitude greater than natural line width.

Introduction to Optical Atomic Spectrometry

Pressure Broadening

Pressure or collisional broadening arises from collisions of the emitting species with other atoms or ions.

The collisions cause small changes in ground state energy levels and the range of emitted wavelengths.

This broadening is 2-3 times greater than the natural line widths.

Introduction to Optical Atomic Spectrometry

Effect of Temperature

Temperature affects the ratio between the number of excited and unexcited atomic particles.

The magnitude of this effect is derived from the Boltzmann equation.

$$N_j/N_0 = P_j/P_0 \exp (- E_j/kT)$$

Introduction to Optical Atomic Spectrometry

Effect of Temperature

Boltzmann equation

$$N_j/N_0 = P_j/P_0 \exp(-E_j/kT)$$

N_j – number of atoms in excited state

N_0 – number of atoms in ground state

k – Boltzmann constant (1.28×10^{-23} J/K)

T – temperature (K)

E_j – energy difference between excited and ground state (J)

P_j and P_0 – statistical factors determined by number of states having equal energy in each quantum level.

Introduction to Optical Atomic Spectrometry

Effect of Temperature

A temperature increase of 10 K can result in a 4% increase in the number of excited atoms, so the atomization temperature must be closely controlled.

Increase temperature increase line broadening.

Optical Atomic Spectrometry

Instrumentation

Consist of radiation source, sample holder (atomizer), wavelength selector, detector, and signal processor.

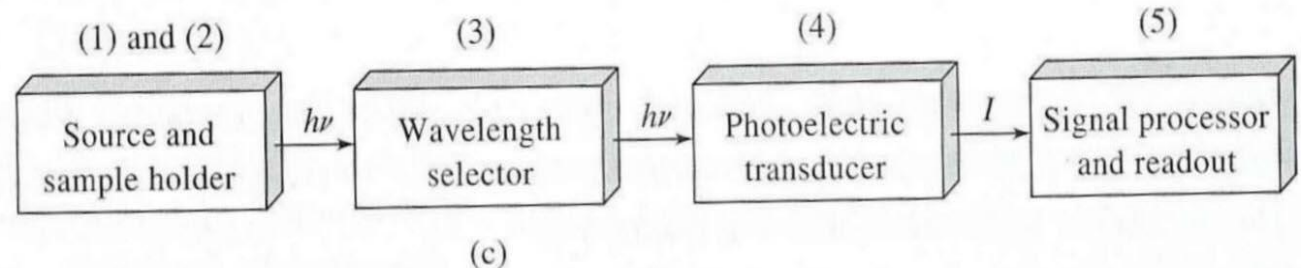
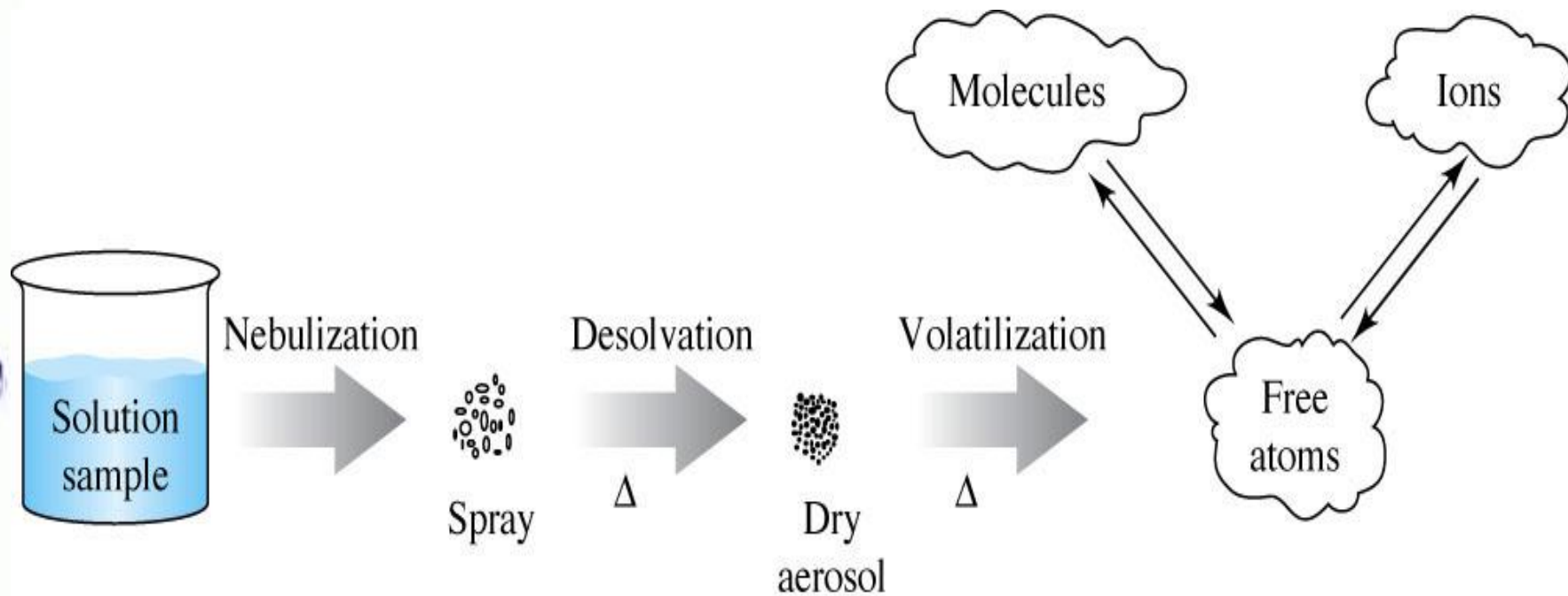

Figure 7-1 Components of various types of instruments for optical spectroscopy: (a) absorption; (b) fluorescence, phosphorescence, and scattering; (c) emission and chemiluminescence.

Optical Atomic Spectrometry



© 2007 Thomson Higher Education

Optical Atomic Spectrometry

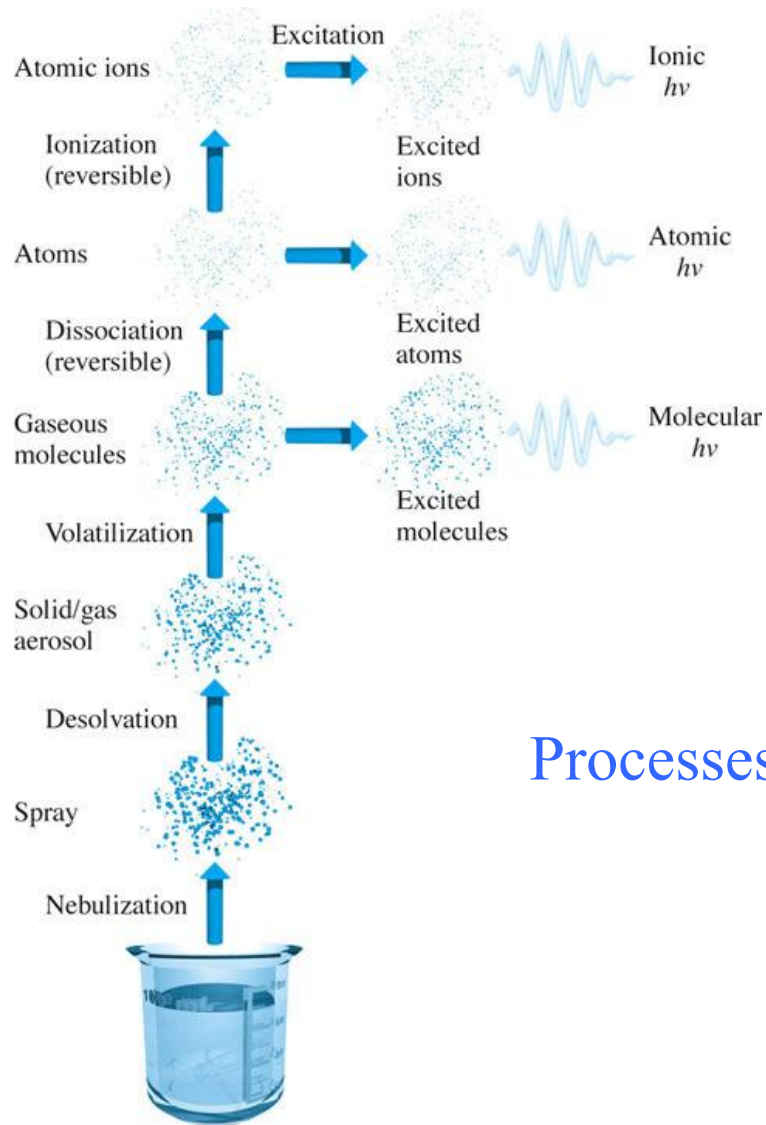

Processes during atomization

Introduction to Optical Atomic Spectrometry

TABLE 8-1 Types of Atomizers
Used for Atomic Spectroscopy

Type of Atomizer	Typical Atomization Temperature, °C
Flame	1700–3150
Electrothermal vaporization (ETV)	1200–3000
Inductively coupled argon plasma (ICP)	4000–6000
Direct current argon plasma (DCP)	4000–6000
Microwave-induced argon plasma (MIP)	2000–3000
Glow-discharge plasma (GD)	Nonthermal
Electric arc	4000–5000
Electric spark	40,000 (?)

Optical Atomic Spectrometry

TABLE 8-2 Methods of Sample Introduction
in Atomic Spectroscopy

Method	Type of Sample
Pneumatic nebulization	Solution or slurry
Ultrasonic nebulization	Solution
Electrothermal vaporization	Solid, liquid, or solution
Hydride generation	Solution of certain elements
Direct insertion	Solid, powder
Laser ablation	Solid, metal
Spark or arc ablation	Conducting solid
Glow-discharge sputtering	Conducting solid

Optical Atomic Spectrometry

Sample Intro Methods - Pneumatic Nebulizers

Used to introduce solution samples into the atomization region.

Optical Atomic Spectrometry

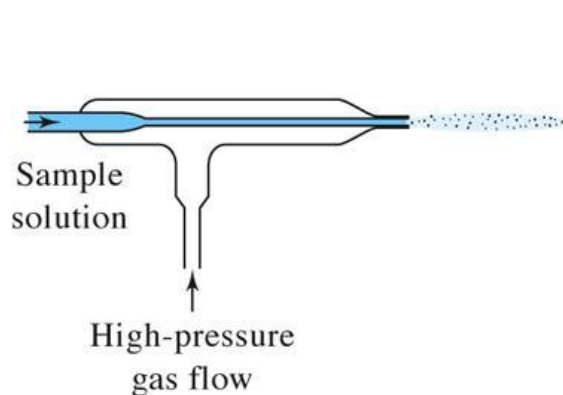

(a)

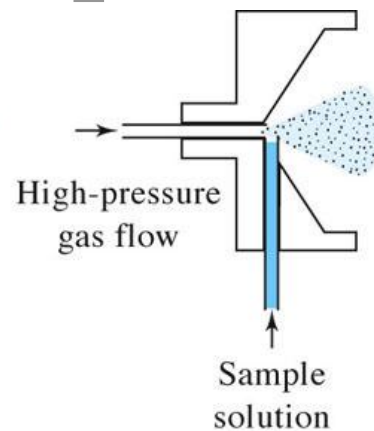

(b)

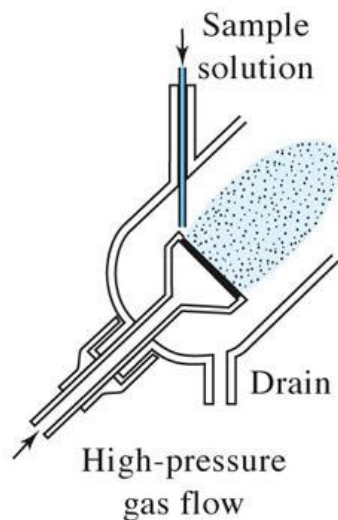

(c)

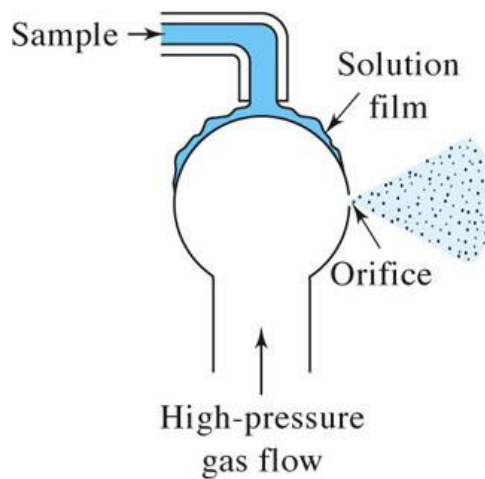

(d)

Optical Atomic Spectrometry

Sample Intro Methods

Ultrasonic Nebulizers

The sample is placed on the surface of a piezoelectric crystal with a frequency of 20 kHz – MHz.

Optical Atomic Spectrometry

Sample Intro Methods

Electrothermal Vaporizers (ETV)

A small liquid or solid sample is placed on a conductor (i.e. C rod or Ta filament).

An electric current evaporates the sample into the argon gas.

Inert gas (Ar) in a chamber carries the vaporized sample into the atomizer.

Optical Atomic Spectrometry

Sample Intro Methods

Electrothermal Vaporizers (ETV)

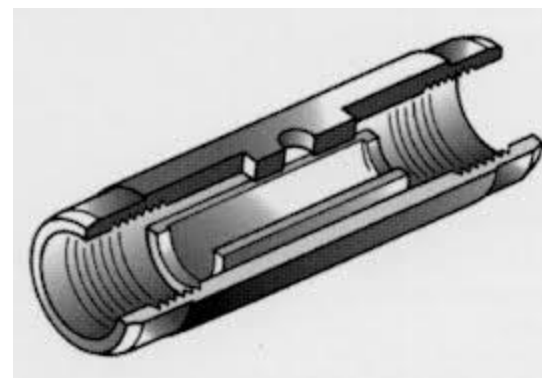
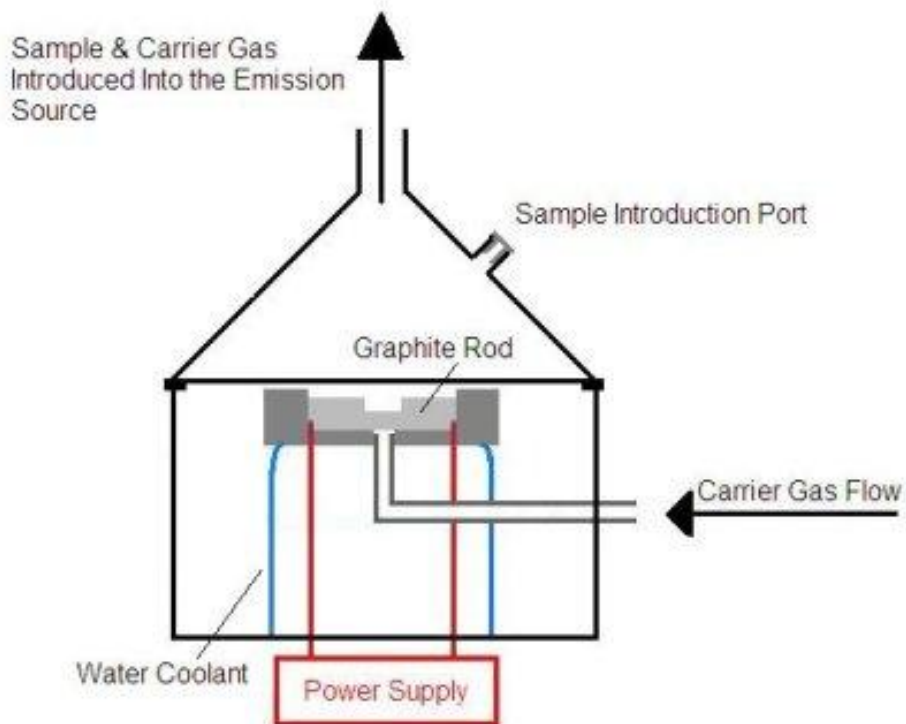

Optical Atomic Spectrometry

Electrothermal Vaporizers (ETV)

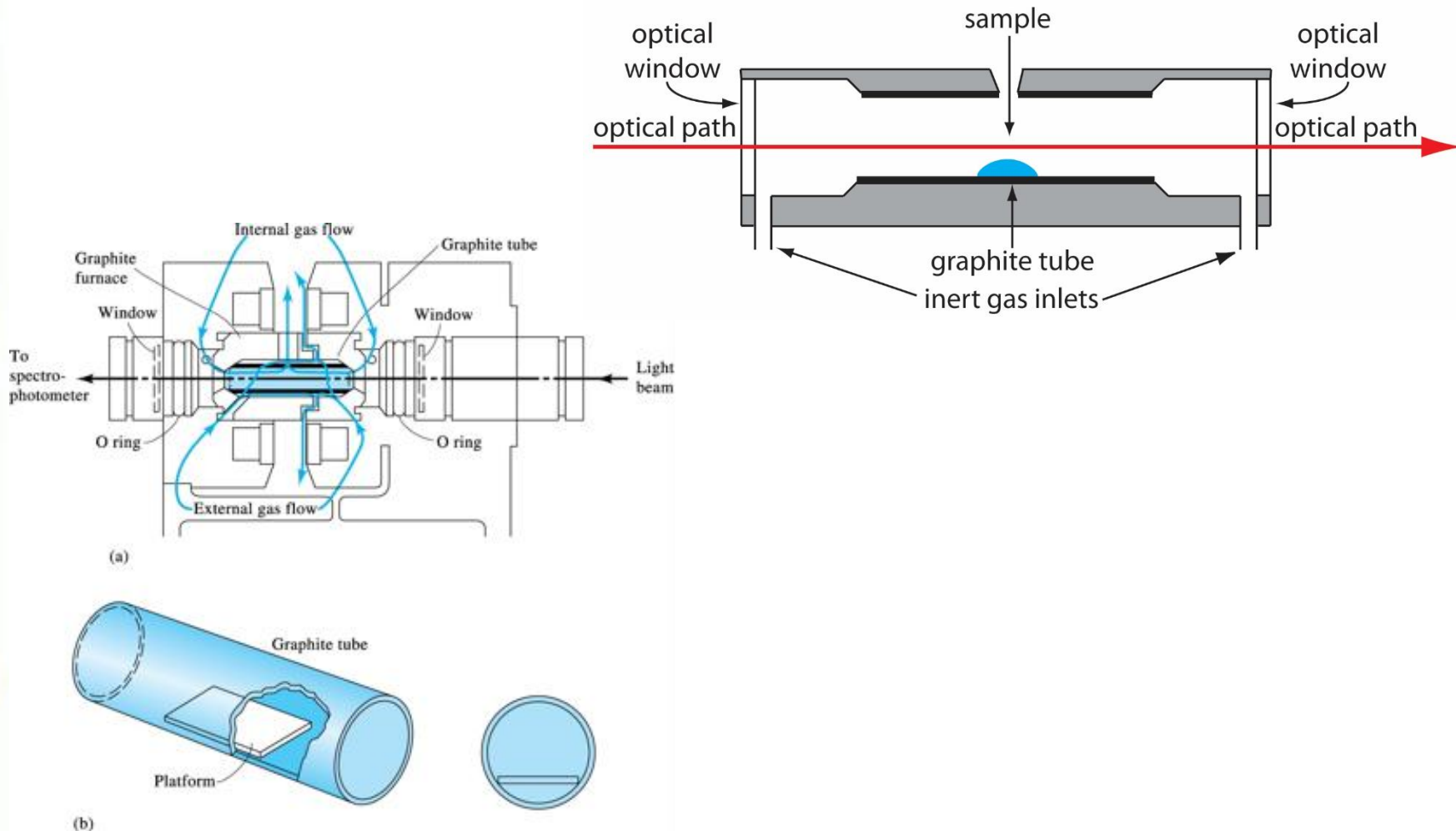

Optical Atomic Spectrometry

Sample Intro Methods

Introduction of Solid Samples

- Direct introduction into atomizer
- Electrothermal vaporization
- Arc/spark or laser ablation
- Slurry nebulization
- Sputtering in a glow discharge device

Optical Atomic Spectrometry

Atomization

Glow Discharge Atomization

Can be used as an accessory to flame instruments.

Consist of cylindrical cell with a small hole.

Sample is pressed against hole and streams of argon hit sample in a hexagonal pattern to sputter sample.

Optical Atomic Spectrometry

Sample Intro Methods

Glow Discharge

Pair of electrodes at a dc potential of 250-1000 V is kept in a low pressure atmosphere (1-10 torr) of argon gas.

Applied potential breaks Ar gas into argon ions and electrons.

Electric field accelerates argon ions to cathode surface containing sample.

When the Ar ions strikes the sample surface, neutral sample atoms are ejected (sputtering) into cell.

Used for metallic and conducting samples.

Optical Atomic Spectrometry

Atomization

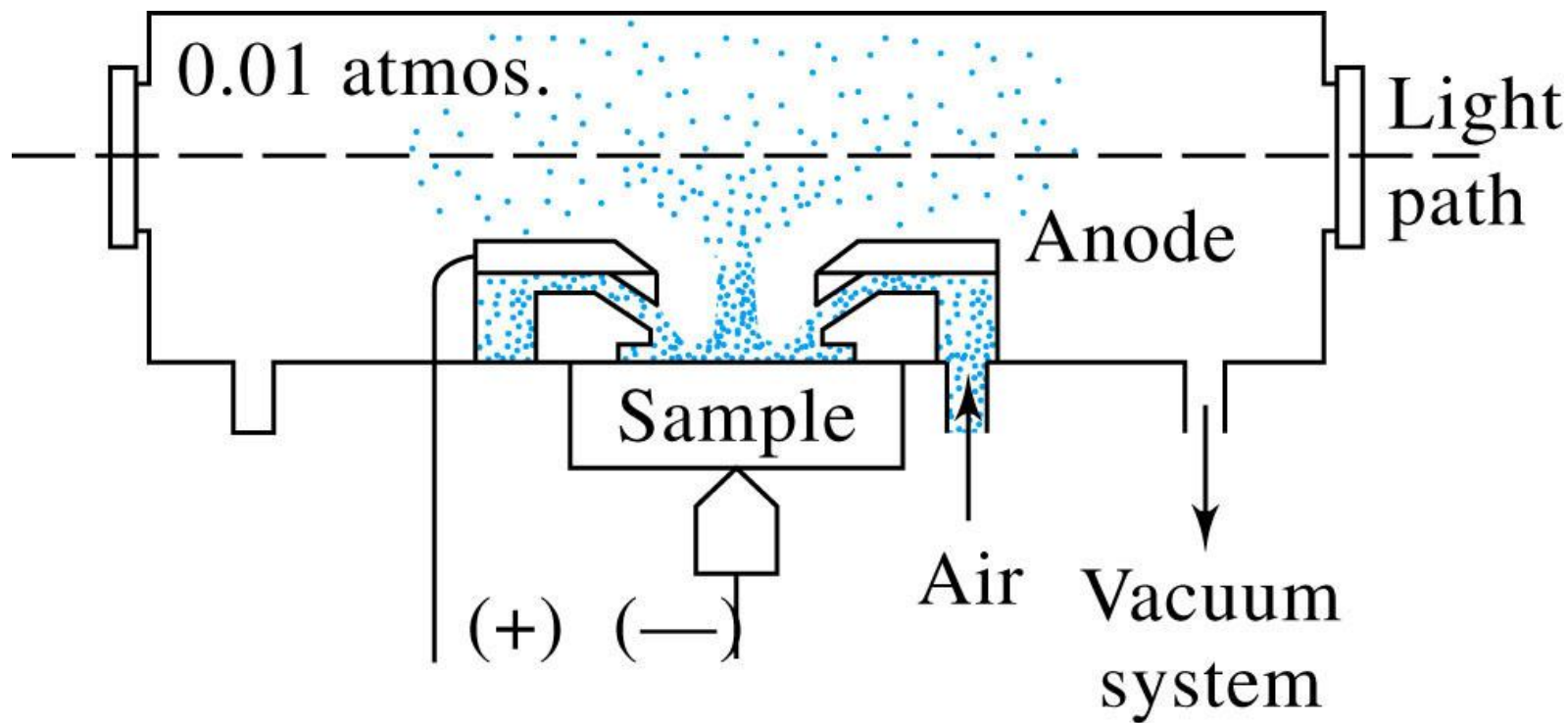

(a)

Optical Atomic Spectrometry

Glow Discharge

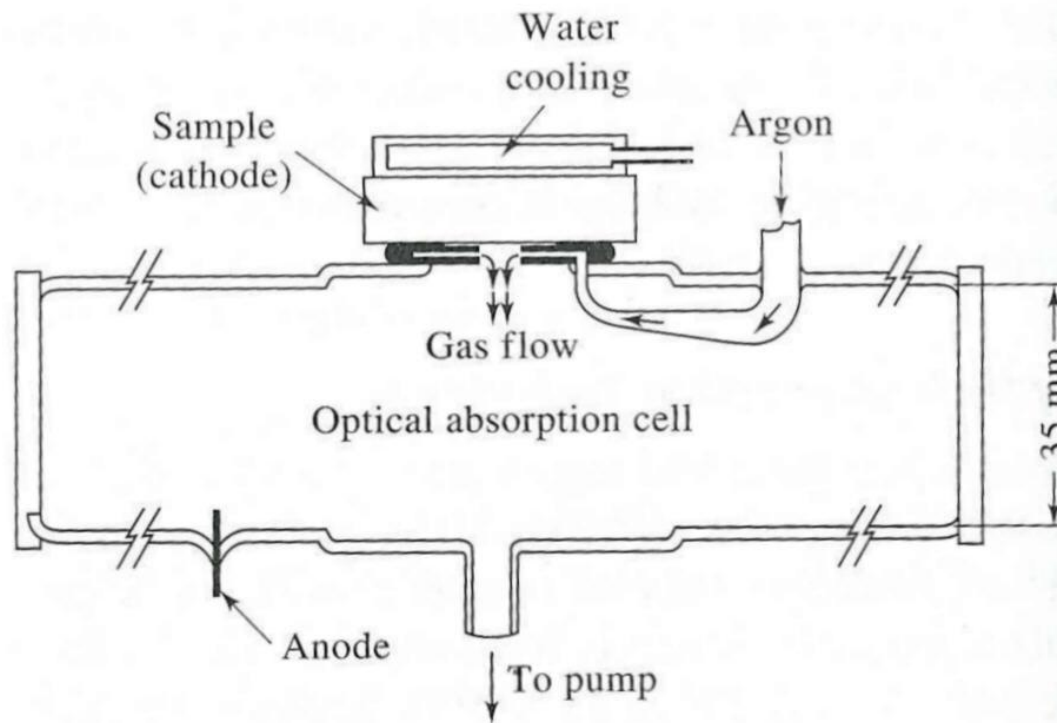
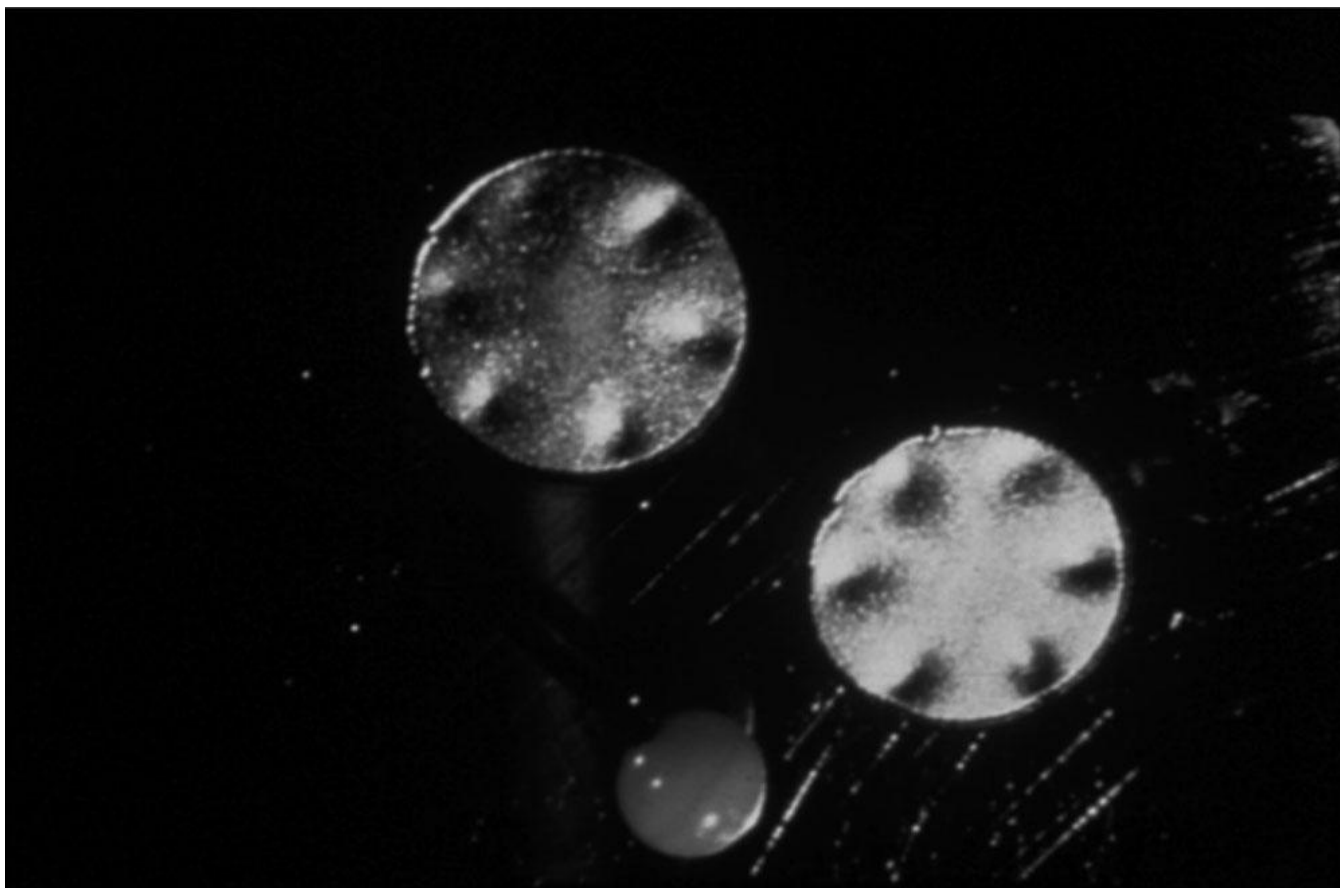

Figure 8-10 A glow discharge atomizer. (From D. S. Gough, P. Hannaford, and R. M. Lowe, *Anal. Chem.*, 1989, 61, 1653. With permission.)

Optical Atomic Spectrometry

Atomization



© 2007 Thomson Higher Education

Assignment

- Read Chapter 18
- HW 8 Chapter 18: 1, 2, 3, 5, 6, 8
- HW 8 Chapter 18 Due 3-4

Exam 2- Lectures 9 to 17 – Wednesday March 4th

- Read Chapter 8
- Read Chapter 9
- HW9 Chapter 8: 1, 4-9
- HW10 Chapter 9: 1-5, 7-9, 19
- HW9 & 10 – Due 3-6

Optical Atomic Spectrometry

Sample Intro Methods

Hydride Generation Techniques

For As, Sb, Sn, Se, Bi, and Pb samples

Example



Volatile hydride is swept into atomization chamber by inert gas.

The hydride decomposes at several hundred degrees and the atom of the analyte is measured.

Technique enhances detection limit by 10-100 times.