



# Chemistry 4631

## Instrumental Analysis

### Lecture 28

# Gas Chromatography

## Instrumentation

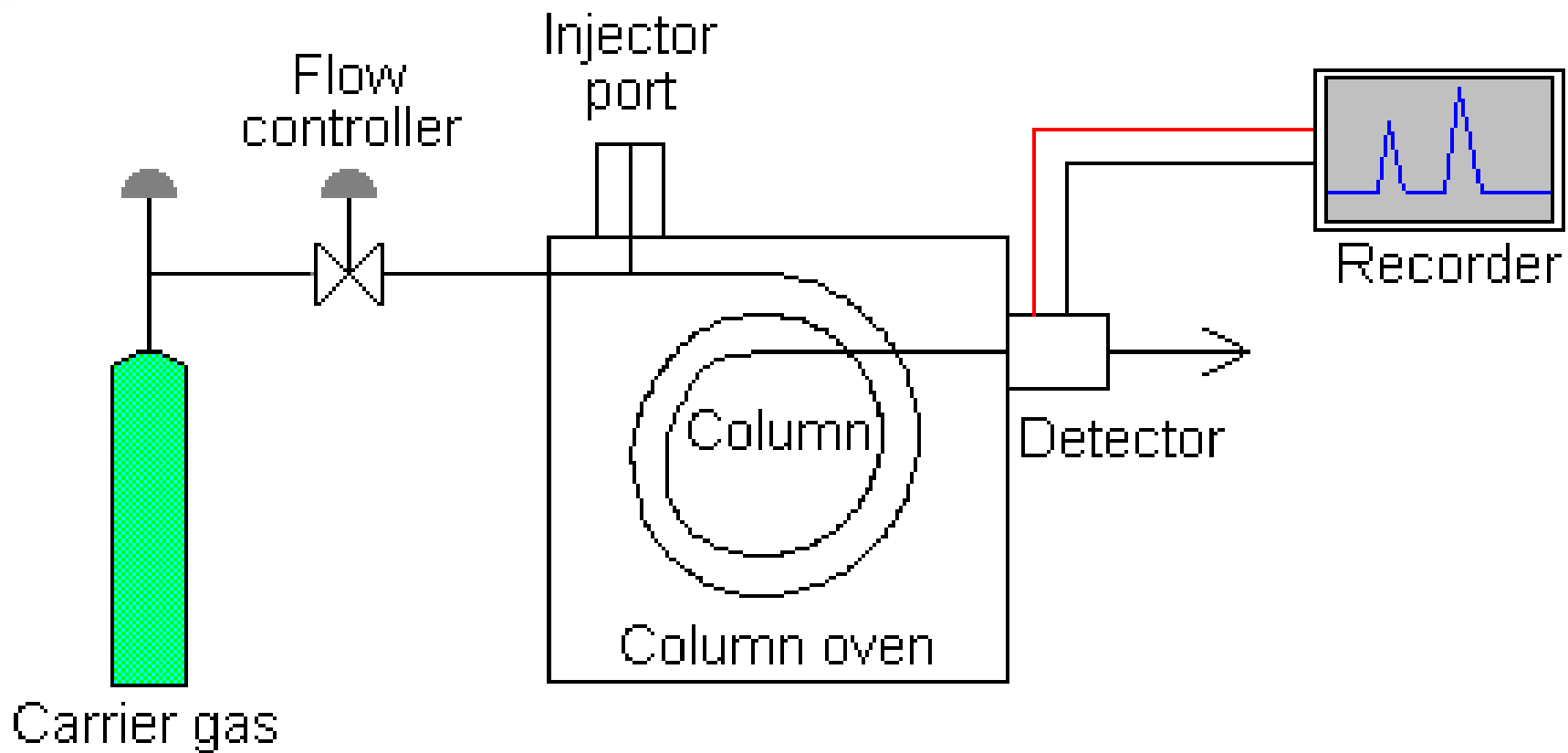

# Gas Chromatography

## Instrumentation

### Detectors

Monitors the column effluent and produces an electrical signal that is proportional to the amount of analyte eluted.

The output signal is recorded as signal intensity versus time.

In principle, any physical or physicochemical property of the carrier gas which deviates from the properties of the carrier gas plus analyte can serve as the basis of detection.

# Gas Chromatography

## Instrumentation

### Detectors

Over 100 detectors have been invented, but relatively few are in common use.

The criteria to consider when selecting a detector are: sensitivity, noise, minimum detectable quantity/detection limit, detection time constant or response time, and selectivity.

# Gas Chromatography

## Instrumentation

### Detectors

#### Common Detectors:

- Thermal Conductivity Detector (TCD)
- Flame Ionization Detector (FID)
- Electron Capture Detector (ECD)
- Alkali Flame Ionization Detector (AFID)
- Flame Photometric Detector (FPD)

# Gas Chromatography

## Instrumentation

### Detectors

**Table 3.17** Classification of the most common gas chromatographic detectors.

Detector	Response	Optimal detection limit	Linear range	Classification
TCD	Organic and inorganic solutes	$10^{-9} \text{ g ml}^{-1}$	$10^4$	Concentration; nondestructive
FID	All organic solutes except formic acid and formaldehyde	$10^{-12} \text{ g ml}^{-1}$	$10^7$	Mass flow-rate; destructive
ECD	Halogenated and nitro compounds	$10^{-16} \text{ mol ml}^{-1}$	$10^3$ – $10^4$ (pulsed)	Concentration; nondestructive
AFID	P- or N-containing solutes	N: $10^{-14} \text{ g s}^{-1}$ P: $10^{-13} \text{ g s}^{-1}$	$10^3$ – $10^5$	Mass flow-rate; destructive
FPD	P- or S-containing solutes	S: $10^{-10} \text{ g s}^{-1}$ P: $10^{-12} \text{ g s}^{-1}$	S: $10^3$ P: $10^5$	Mass flow-rate; destructive

# Gas Chromatography

## Instrumentation

### Detectors

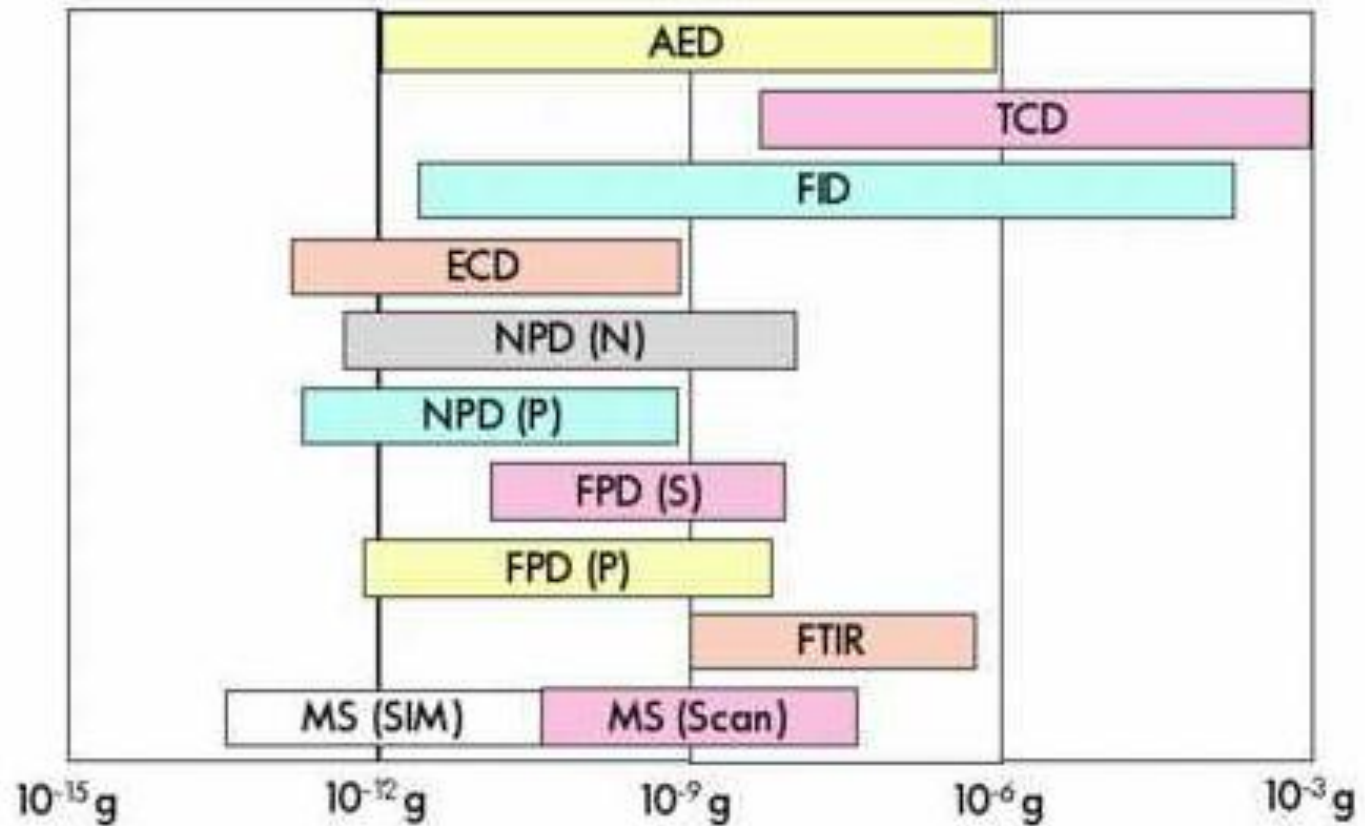

# Gas Chromatography

## Instrumentation

### Detectors

#### Thermal Conductivity Detector (TCD)

First detector commercially available for GC,  
overall universal detector.

Filament – Pt, Pt alloy, W or W alloys.

# Gas Chromatography

## Instrumentation

### Detectors

#### Thermal Conductivity Detector (TCD)

Filaments are mounted in two flow channels, one reference, the other analytical.

Filaments are heated and excess gas is carried away by the gas flow at a rate dependent upon the thermal conductivity of the gas.

Thermal equilibrium is established for the carrier gas.

# Gas Chromatography

## Instrumentation

### Detectors

### Thermal Conductivity Detector (TCD)

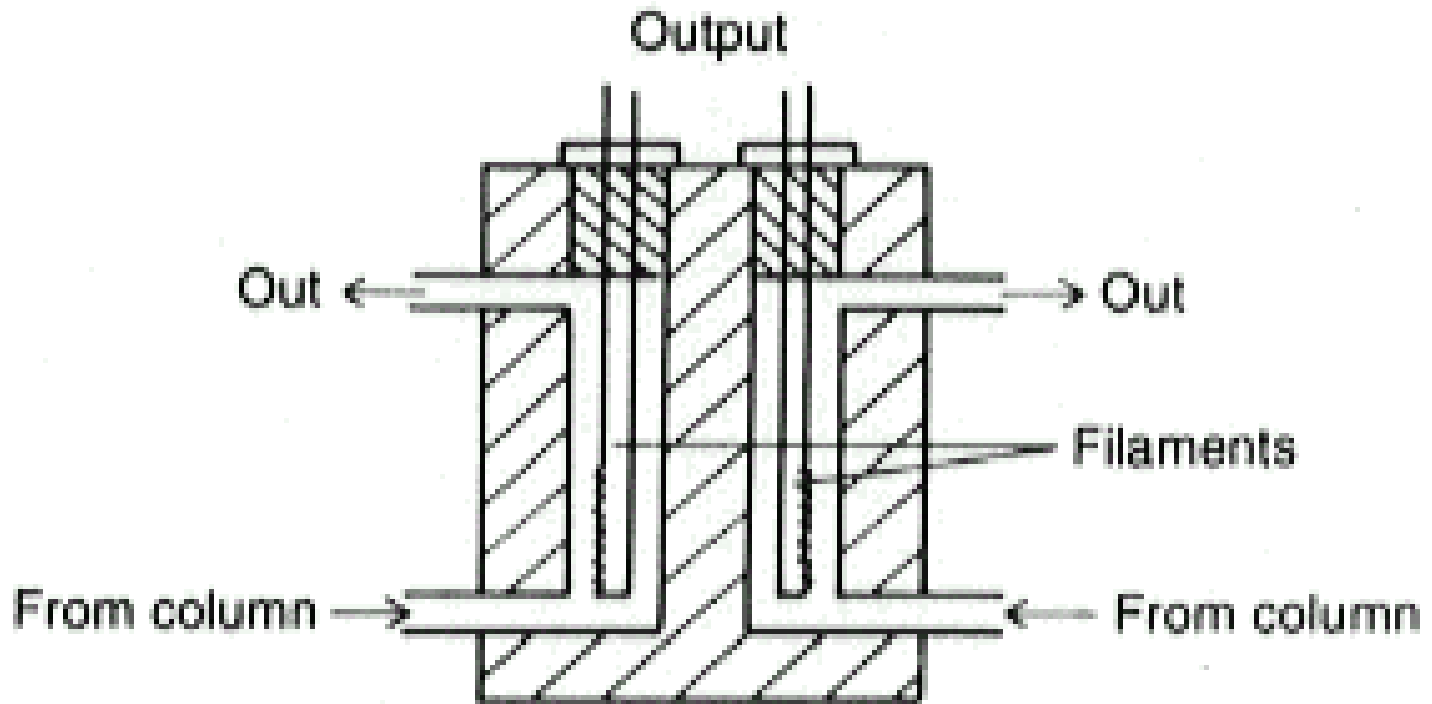

# Gas Chromatography

## Instrumentation

### Detectors

#### Thermal Conductivity Detector (TCD)

When a solute passes through the analyte channel, the thermal conductivity of the carrier stream is changed and the rate of heat loss will change for the filament.

This causes the temperature and thus the resistance of the filament to change.

The signal is a difference in current from the reference.

# Gas Chromatography

## Instrumentation

### Detectors

#### Thermal Conductivity Detector (TCD)

For newer detectors the current flowing through the filaments is adjusted electronically to maintain a constant temperature and the change in applied potential is monitored ( $V = IR$ ). Bridge circuit used is a Wheatstone Bridge.

# Gas Chromatography

## Instrumentation

### Detectors

### Thermal Conductivity Detector (TCD)

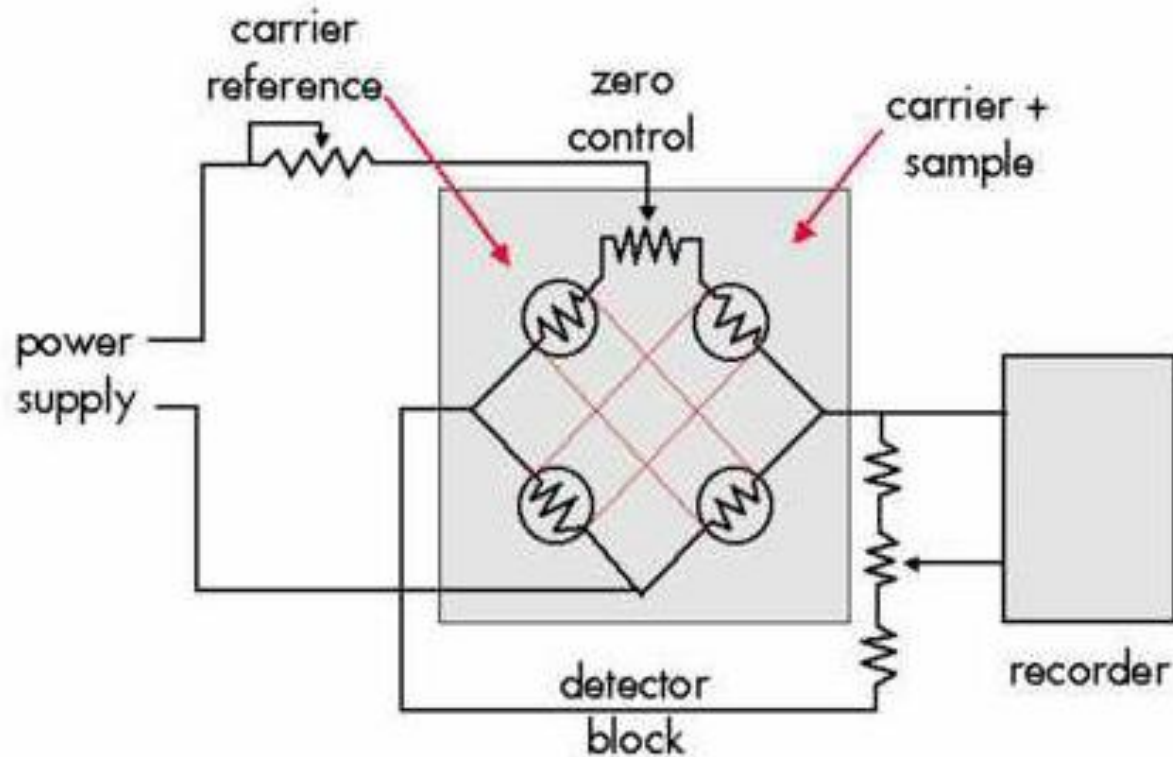

# Gas Chromatography

## Instrumentation

### Detectors

#### Thermal Conductivity Detector (TCD)

**When only gas flows all resistors have the same value and there is no voltage difference measured. When a solute elutes from the column, resistance increases and a voltage difference is measured. Any changes in room temperature or column bleed affect each side the same and cancel each other out.**

# Gas Chromatography

## Instrumentation

### Detectors

#### Thermal Conductivity Detector (TCD)

TCD responds to any compound, regardless of structure, whose thermal conductivity differs from that of the carrier gas.

It is a standard detector for determination of inorganic gases –  $\text{H}_2$ ,  $\text{O}_2$ ,  $\text{N}_2$ ,  $\text{CS}_2$  and  $\text{H}_2\text{O}$ .

Most analytes have low thermal conductivities, so the highest sensitivity is attained by using a carrier gas of very high thermal conductivity H or He (usually a 10 factor increase)

# Gas Chromatography

## Instrumentation

### Detectors

#### Thermal Conductivity Detector (TCD)

Linear dynamic range  $10^3$ .

TCD is housed (heated) separate from the column oven because temperature control is crucial. Also filament must be protected from  $O_2$  while hot.

TCD is classified as a concentration/nondestructive detector. The response is proportional to the relative concentration of analyte in the carrier gas (i.e. mass of solute per unit volume of carrier gas).

# Gas Chromatography

## Instrumentation

### Detectors

#### Flame Ionization Detector (FID)

FID is the standard workhorse detector for the GC. It has a stainless steel jet which allows carrier gas to mix with H<sub>2</sub> gas and flow to a microburner tip, which is supplied by a high flow of air for combustion.

# Gas Chromatography

## Instrumentation

### Detectors

### Flame Ionization Detector (FID)

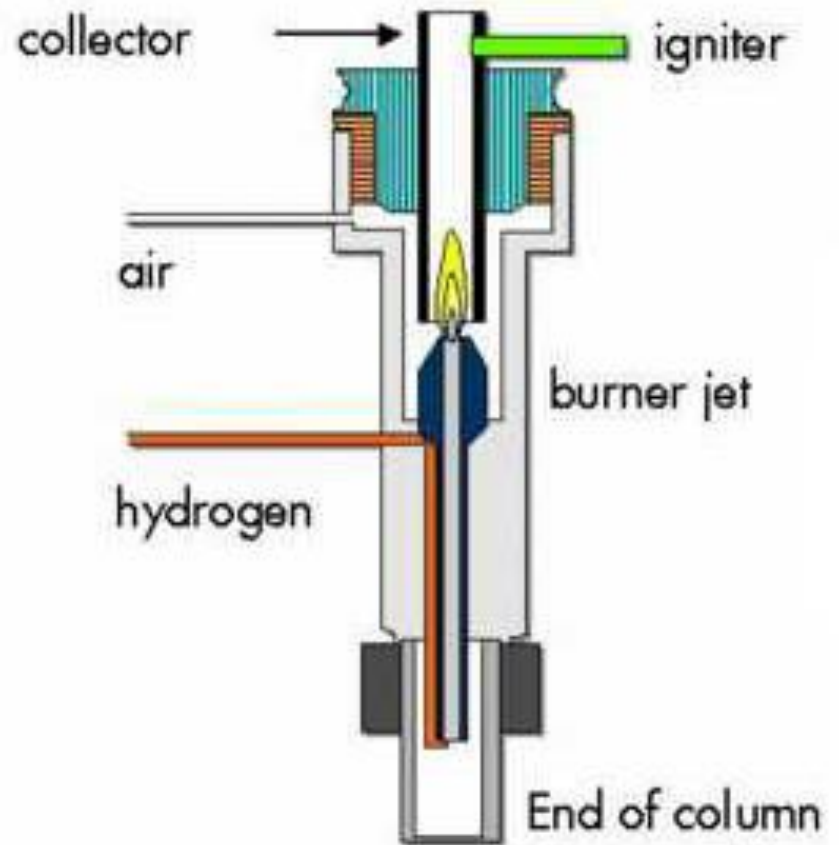

# Gas Chromatography

## Instrumentation

### Detectors

#### Flame Ionization Detector (FID)

Ions produced by combustion are collected at a pair of polarized electrodes to give a signal (increase in current).

This current is amplified and recorded.

The ionization efficiency is low but sufficient enough to give excellent sensitivity and linearity.

For organic compounds the signal is a proportional to the total mass of carbon and hydrogen in the analyte (Oxygen and halogens affect this response).

# Gas Chromatography

## Instrumentation

### Detectors

#### Flame Ionization Detector (FID)

FID is a mass flow detector – it depends directly on flow rate of carrier gas, produces a signal proportional to the absolute mass of solute vapor reaching the detector per unit time. The area response for a compound does not change with small changes in carrier flow.

The response units are coulombs/gram of carbon.

# Gas Chromatography

## Instrumentation

### Detectors

#### Flame Ionization Detector (FID)

The effective carbon number (ECN) has been developed to estimate the relative response for any compound.

Response is based on the number of carbon and if other elements like halogens or oxygen are present which reduce combustion.

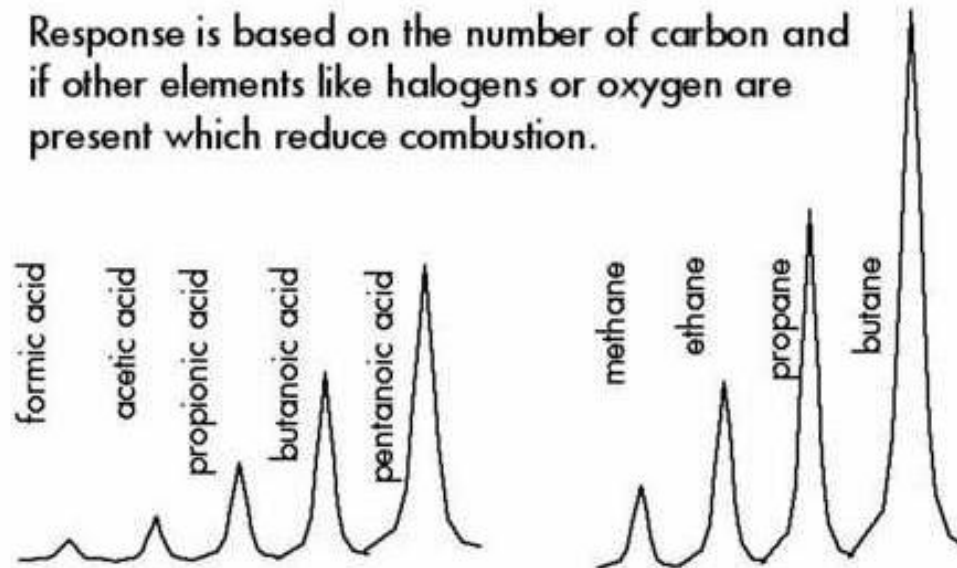

# Gas Chromatography

## Instrumentation

### Detectors

TABLE 5.3 Contributions to Effective Carbon Number

Atom	Type	Effective Carbon No. Contribution
C	Aliphatic	1.0
C	Aromatic	1.0
C	Olefinic	0.95
C	Acetylenic	1.30
C	Carbonyl	0.0
C	Nitrile	0.3
O	Ether	-1.0
O	Primary alcohol	-0.6
O	Secondary alcohol	-0.75
O	Tertiary alcohol, esters	-0.25
Cl	Two or more on single aliphatic C	-0.12 each
Cl	On olefinic C	+0.05
N	In amines	Similar to O in corresponding alcohols

# Gas Chromatography

## Instrumentation

### Detectors

#### Flame Ionization Detector (FID)

Example:

ECN of n-propanol

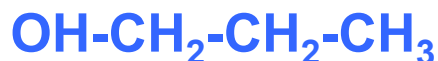

3 aliphatic carbons and one primary alcohol oxygen

$$\text{ECN} = (3 \times 1.0) + (1 \times -0.6) = 3 + (-0.6) = 2.4$$

Butyric acid



$$\text{ECN} = (3 \times 1.0) + (1 \times 0.0) = 3.0$$

# Gas Chromatography

## Instrumentation

### Detectors

#### Flame Ionization Detector (FID)

- Aliphatic carbon  $\rightarrow$  C-C-C-C
- Aromatic carbon  $\rightarrow$  benzene
- Olefinic carbon  $\rightarrow$  alkene
- Acetylene carbon  $\rightarrow$  H-C $\equiv$ C-H
- Carbonyl carbon  $\rightarrow$  aldehyde, ketone, carboxylic acid
- Nitrile  $\rightarrow$  CN
- Ether oxygen  $\rightarrow$  (ROR')
- Primary alcohol  $\rightarrow$  CH<sub>3</sub>CH<sub>2</sub>OH
- Secondary alcohol  $\rightarrow$  (CH<sub>3</sub>)<sub>2</sub>CHOH
- Ester or 3<sup>rd</sup>  $\rightarrow$  (CH<sub>3</sub>)<sub>3</sub>COH

# Gas Chromatography

## Instrumentation

### Detectors

#### Electron Capture Detectors (ECD)

Most widely used of the selective detectors due to its high sensitivity to organohalogen compounds of environmental interest (polychlorinated biphenyls, pesticides...)

Requires higher expertise and experience to achieve consistent results.

# Gas Chromatography

## Instrumentation

### Detectors

#### Electron Capture Detectors (ECD)

Consists of a chamber containing a radioactive source (usually  $^{63}\text{Ni}$ , occasionally  $^3\text{H}$ ).

$^{63}\text{Ni}$  can be used up to  $380^\circ\text{C}$ , without too much loss of radioactive material.

# Gas Chromatography

## Instrumentation

### Detectors

#### Electron Capture Detectors (ECD)

Traditional construction is a parallel plate design – more recent type is a concentric tube design with lower dead volume, shape optimizes the electron capture process.

Radioactive source emits high energy  $\beta$  particles capable of ionizing the carrier gas to produce secondary thermal electrons. Each  $\beta$  particle produces 100 – 1000 thermal electrons by collision.

# Gas Chromatography

## Instrumentation

### Detectors

### Electron Capture Detectors (ECD)

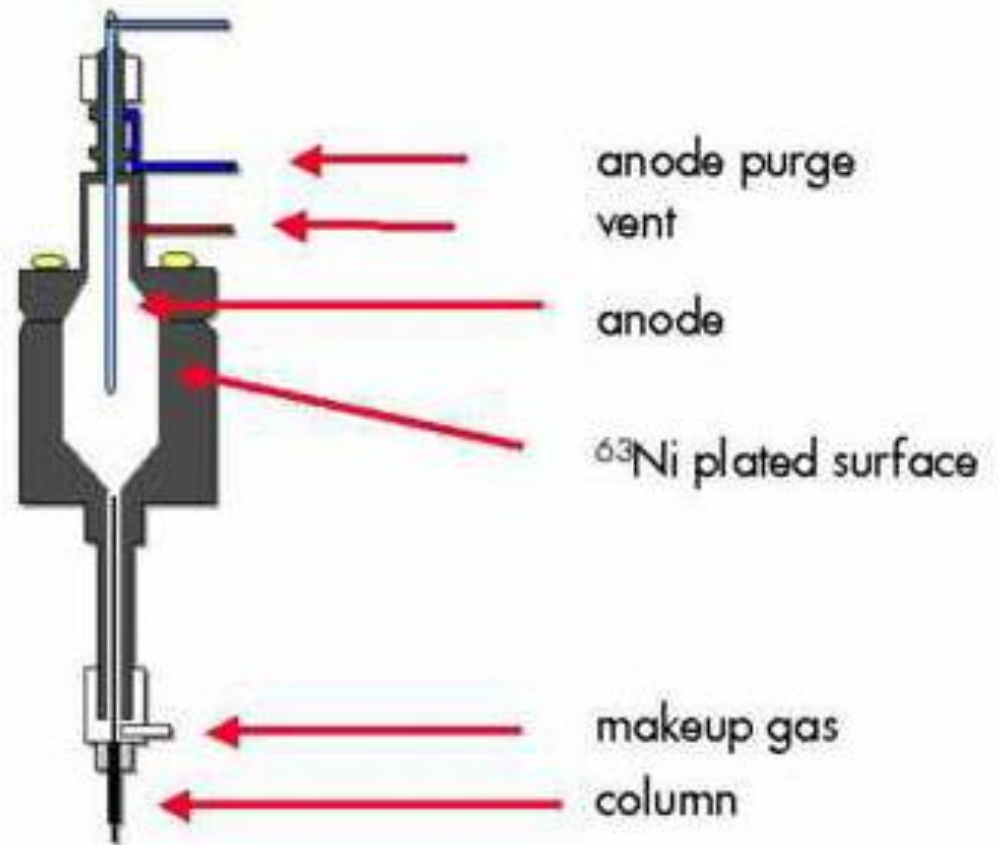

# Gas Chromatography

## Instrumentation

### Detectors

#### Electron Capture Detectors (ECD)

The thermal electrons produced are collected at an anode that has a potential of ~50 V.

This is the background or standing current.

When an electrophilic analyte enters the detector it collides with a thermal electron and reduces the background current by either a dissociative or non-dissociative reaction.

# Gas Chromatography

## Instrumentation

### Detectors

#### Electron Capture Detectors (ECD)

$AB + e^- \rightarrow AB^-$  (nondissociative capture, favored at lower temperatures)

$AB + e^- \rightarrow A + B^-$  (dissociative capture, favored at higher temperatures)

# Gas Chromatography

## Instrumentation

### Detectors

#### Electron Capture Detectors (ECD)

**ECD's are easily contaminated so water and oxygen must be removed from the carrier gas, low bleed columns are essential, and samples must be dilute to avoid saturation.**

# Gas Chromatography

## Instrumentation

### Detectors

#### Alkali Flame Ionization Detector (AFID)

Also known as the Thermionic Ionization Detector (TID) or Nitrogen-phosphorous Detector (NPD).

# Gas Chromatography

## Instrumentation

### Detectors

#### Alkali Flame Ionization Detector (AFID)

It is a modified FID – a constant supply of an alkali metal salt (i.e. Rubidium chloride) is introduced into the flame.

A ceramic or silica bead is coated with the alkali metal salt and placed between the flame jet and ion collector.

The bead is heated between 600 – 800°C. The alkali salt volatilizes (positive ion produced) and passes into the flame and is ionized.

The ions in the flame create a constant standing current.

# Gas Chromatography

## Instrumentation

### Detectors

### Alkali Flame Ionization Detector (AFID)

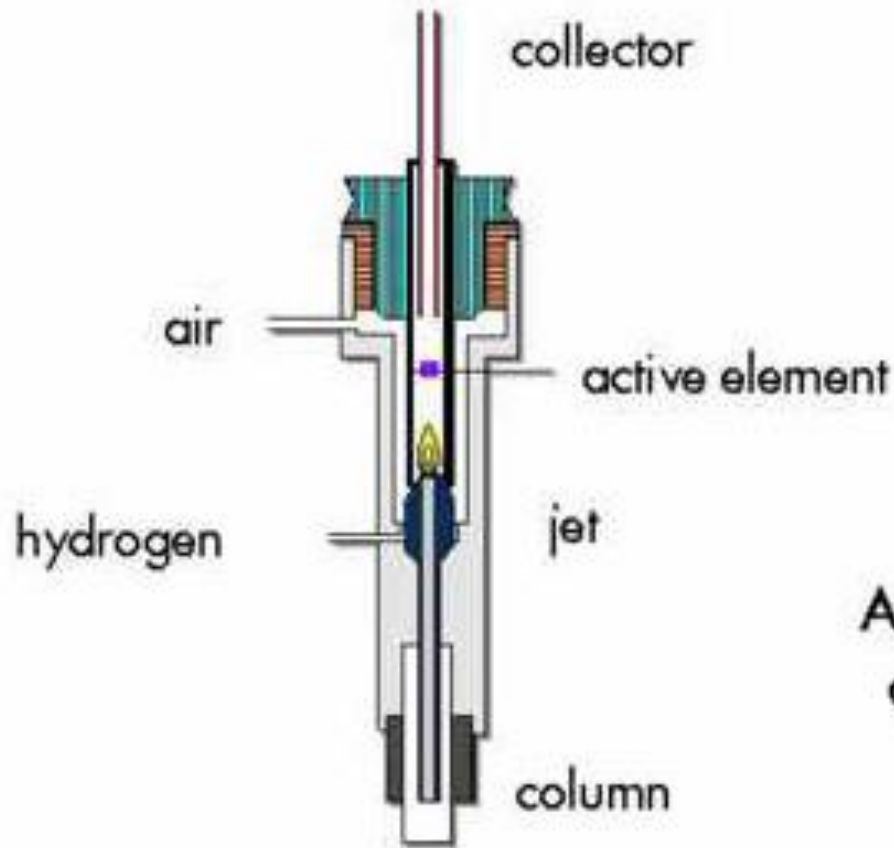

Active element is a K or Rb salt.

# Gas Chromatography

## Instrumentation

### Detectors

#### Alkali Flame Ionization Detector (AFID)

Instead of a flame, a low temperature plasma of  $H_2$  can be used.

AFID is selective to compounds containing nitrogen and phosphorous.

Silylated compounds contaminate the AFID.

Bead lifetimes are low – 100-1000 hours operating time.

Mechanism unknown.

# Gas Chromatography

## Instrumentation

### Detectors

#### Flame Photometric Detector (FPD)

**1<sup>st</sup> Flame combust and decompose solvent molecules (can quench sulfur emission).**

**The elected species passes into a flame or plasma inside a shielded jet which produces atoms and molecules species.**

**The atoms and molecules are in an excited state and when they return to the ground state, they emit at wavelengths characteristic of the atomic line or molecular band.**

# Gas Chromatography

## Instrumentation

### Detectors

### Flame Photometric Detector (FPD)

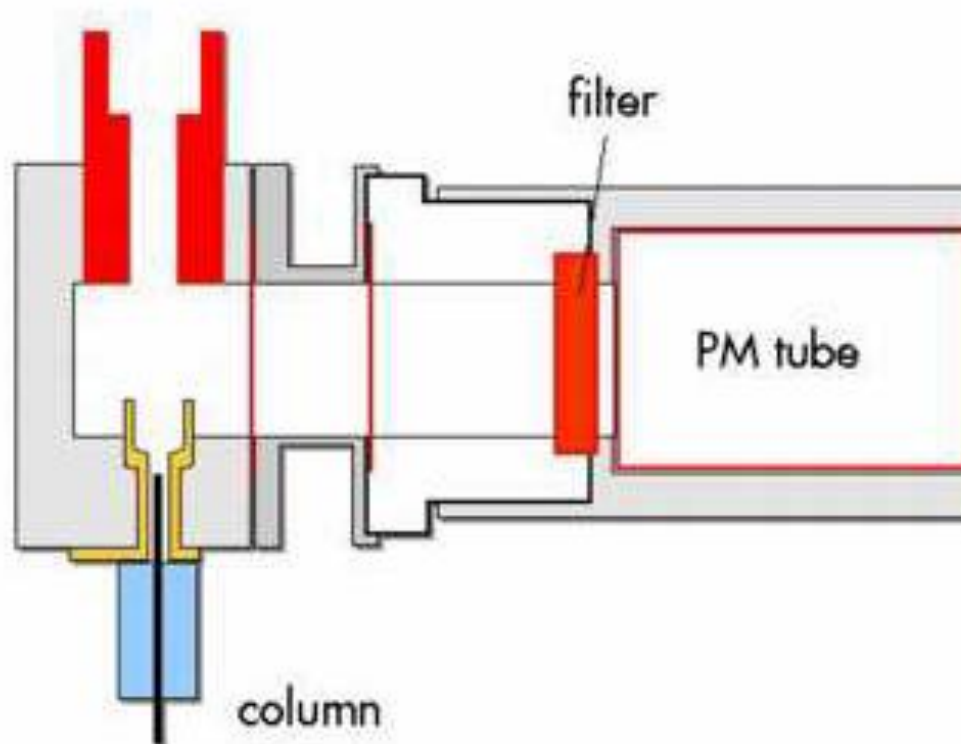

# Gas Chromatography

## Instrumentation

### Detectors

#### Flame Photometric Detector (FPD)

Specific detector for sulfur or phosphorous (sub ng levels) used mostly for pesticides.

Combustion of phosphorous and sulfur compounds – produce excited species –  $\text{HPO}^*$  and  $\text{S}_2^*$ , which emit at 526nm and 394nm, respectively.

Response is linear for phosphorous but non-linear for sulfur (varies as the species of the amount of sulfur present).

# Gas Chromatography

## Instrumentation

### Detectors

#### Photoionization Detector (PID)

Specific detector for compounds ionized by UV.

UV light is used to directly ionize the sample.  
The resulting current is measured.

Limit of detection - 2 pg carbon/sec

Linear Range -  $10^7$

# Gas Chromatography

## Instrumentation

### Detectors

### Photoionization Detector (PID)

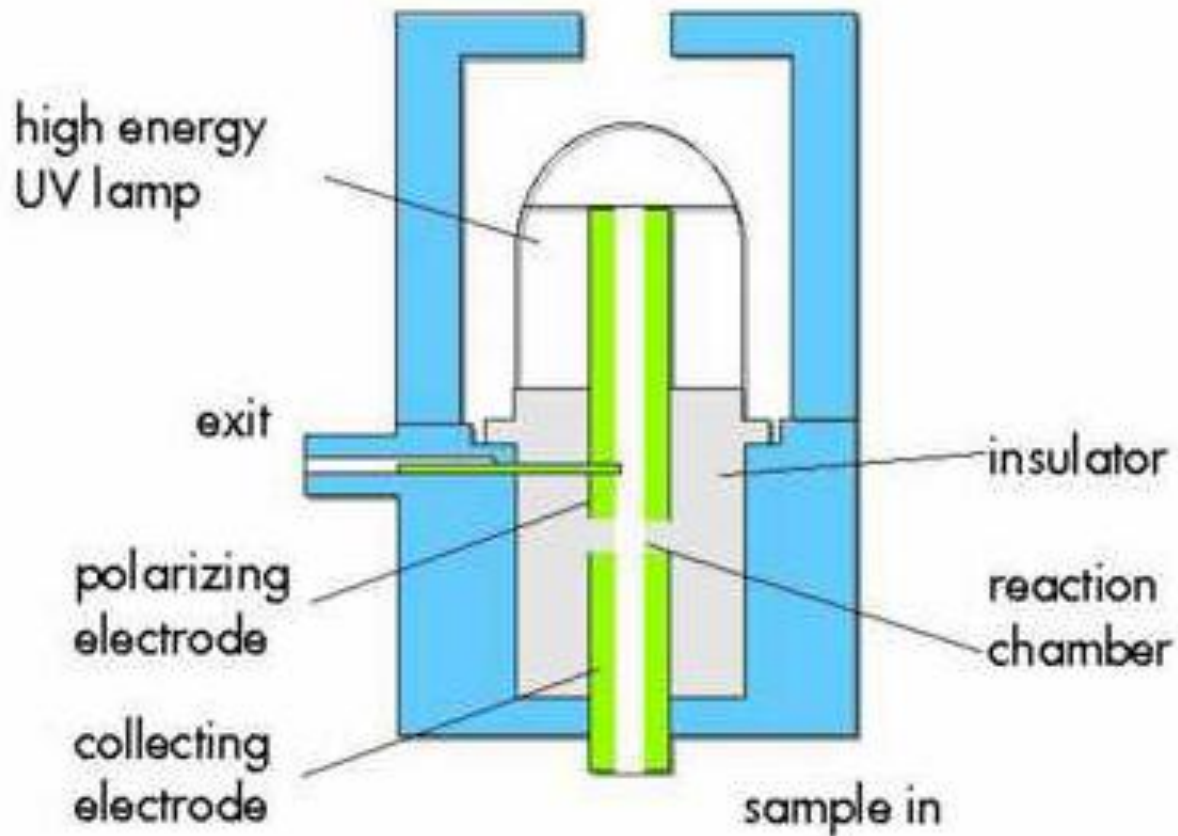

# Gas Chromatography

## Instrumentation

### Detectors

#### Photoionization Detector

Since only a small (very reproducible but basically unknown) fraction of the analyte molecules are actually ionized in the PID chamber, this is considered a nondestructive GC detector.

Therefore, the exhaust port of the PID *can be* connected to another detector in series with the PID. In this way data from two different detectors can be taken simultaneously, and selective detection of PID responsive compounds augmented by response from another detector.

# Gas Chromatography

## Instrumentation

### Detectors

#### Photoionization Detector

The major challenge here is to make the design of the ionization chamber and the downstream connections to the second detector as low volume as possible so that peaks that have been separated by the GC column do not broaden out before detection.

# Gas Chromatography

## Instrumentation

### Detectors

#### Photoionization Detector

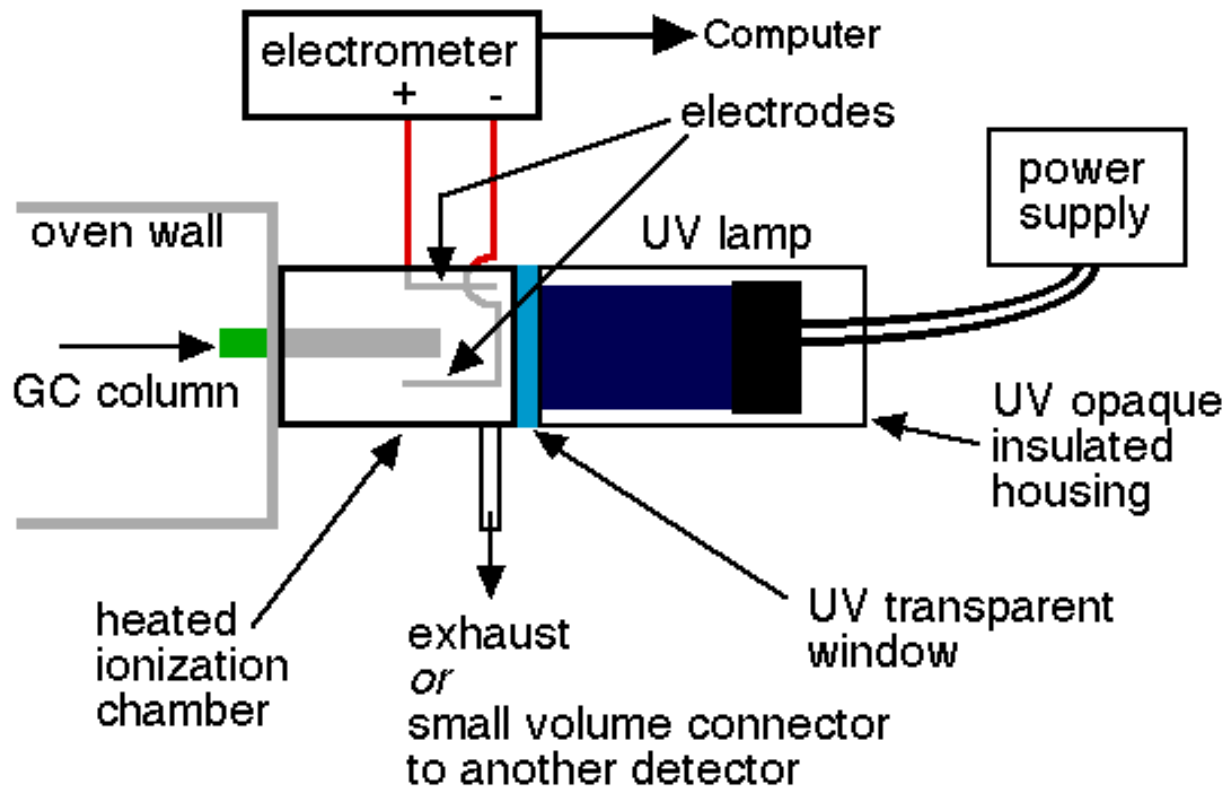

# Gas Chromatography

## Instrumentation

### Detectors

#### Common Detectors:

- Thermal Conductivity Detector (TCD)
- Flame Ionization Detector (FID)
- Electron Capture Detector (ECD)
- Alkali Flame Ionization Detector (AFID)
- Flame Photometric Detector (FPD)
- Photoionization Detector (PID)
- **Mass Spectrometry Detector (MS)**

# Gas Chromatography

## Instrumentation

Detectors  
Mass  
Spectrometry

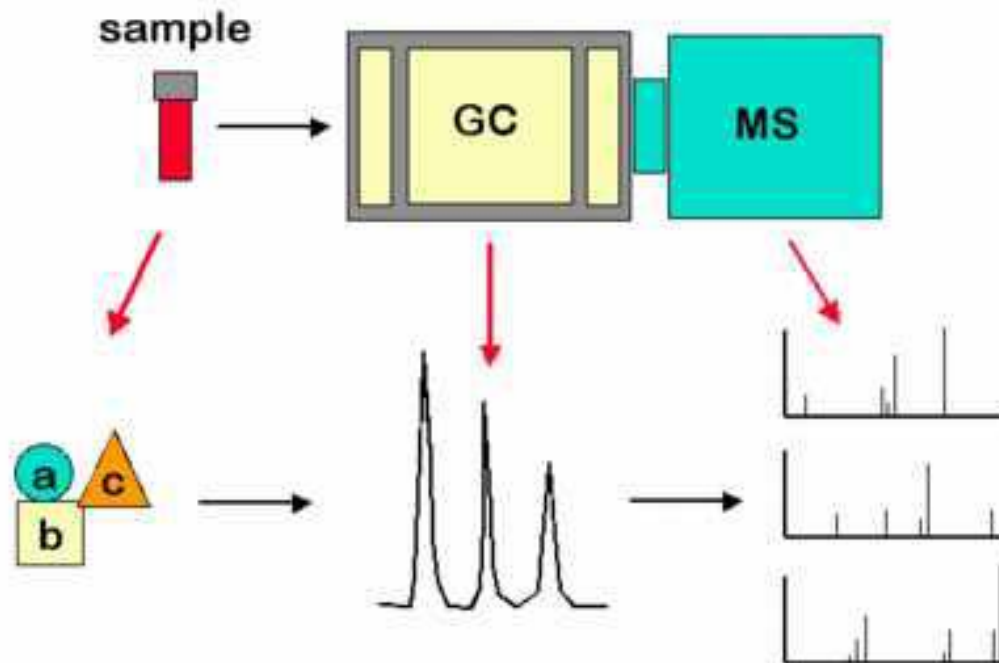

# Gas Chromatography

## Instrumentation

### Detectors

### Mass Spectrometry

Analytes from GC column are fed into the MS ion source where the molecules are ionized.

The molecular ions break apart or “fragment”.

These fragments are separated according to their mass-to-charge ratio ( $m/z$ ) and the intensity (ion current) of each type of ion is recorded.

Plot total ion current versus  $m/z$  – mass spectrum.

# Gas Chromatography

## Instrumentation

**Detectors**

**Mass Spectrometry**

**GC/MS Interface**

**GC column is at atm pressure, while MS is under high vacuum.**

**Interface must efficiently convey sample components between GC and MS**

# Gas Chromatography

## Instrumentation

### Detectors

#### GC/MS Interface - Transfer Line

Connects column to MS port by a tube made up of fused silica.

Tube must not adsorb effluent.

Tube heated to within 25 °C of the column temperature.

Tube volume is small to minimize band spreading.

# Gas Chromatography

## Instrumentation

### Detectors

**GC/MS Interface - Capillary Column interface**

**Direct Transfer**

**Column is threaded directly into MS ion source.**

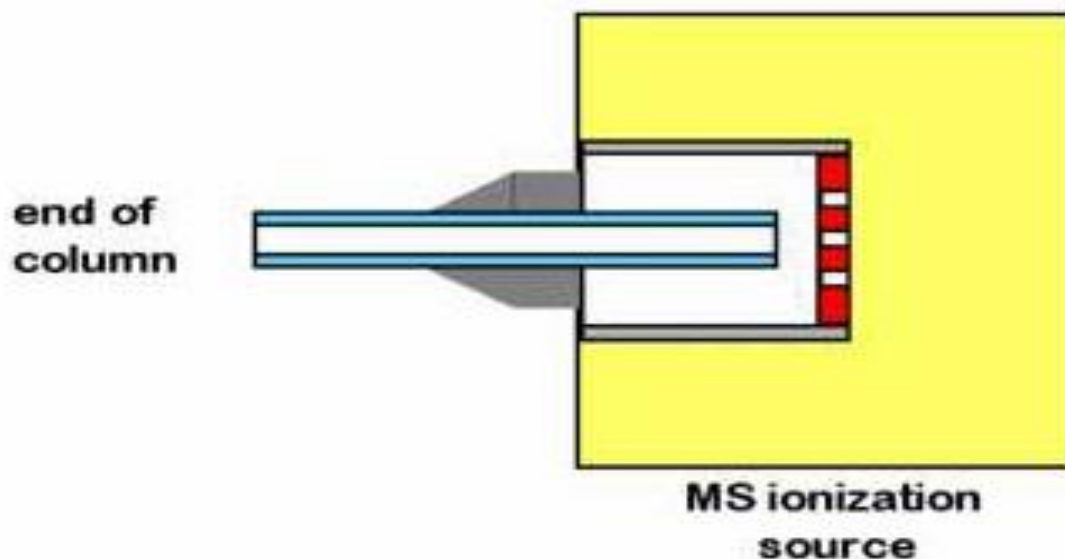

# Gas Chromatography

## Instrumentation

### Detectors

#### GC/MS Interface - Open Split

Restrictor or transfer line limits flow of GC effluent into MS.

Excess effluent swept away by purge gas ( $N_2$  or He)

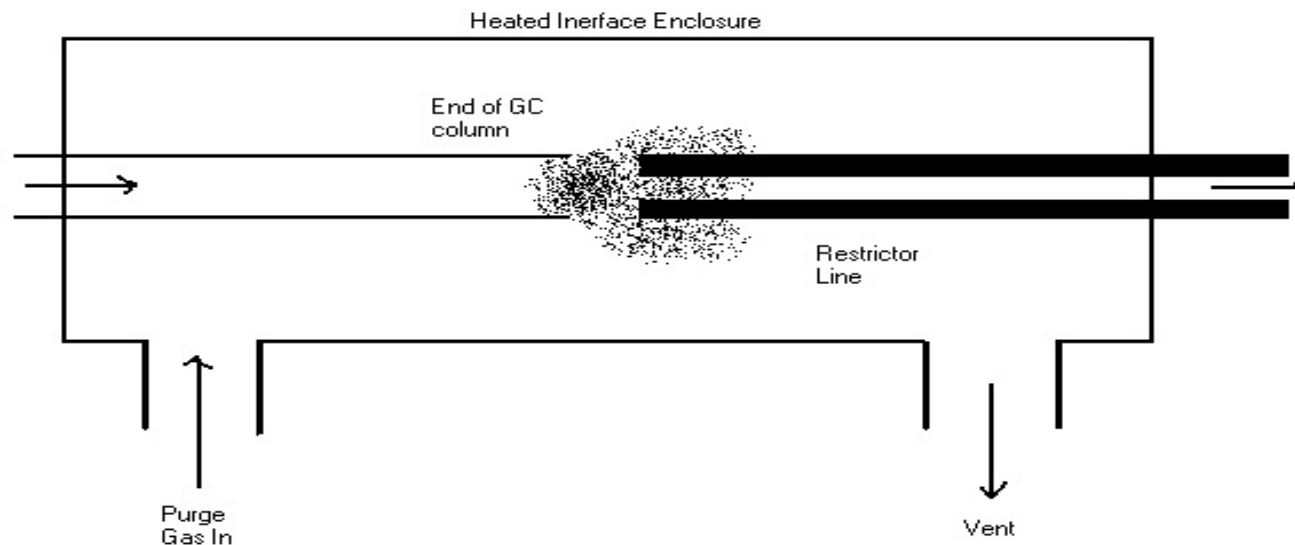

# Gas Chromatography

## Instrumentation

### Detectors

### GC/MS Interface - Jet separator

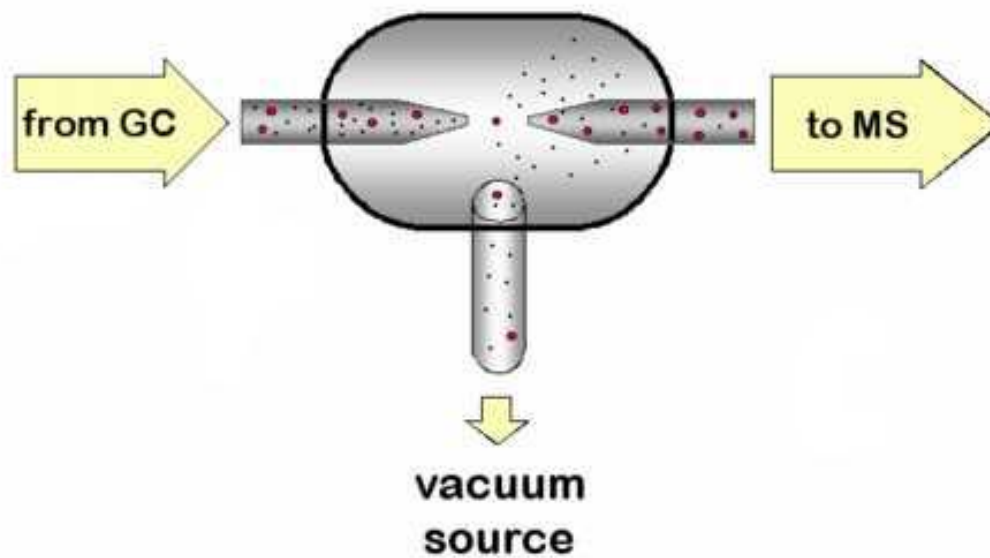

# Assignment

- Read Chapter 27
- HW16 Chapter 27: 1-5, 11-19 & 21-23
- HW16 Chapter 27 Due 4/13/26

