



# Electrochemistry

CHEM 5390

# Introduction

## Conduction in a cell

Charge is conducted by:

- **The electrodes and leads (circuits) – involves electrons**
- The solution – involves migration of cations and anions
- The interface – involves oxidation and reduction

# Electronics

Electronics and Circuits are also important concepts in Electrochemistry.

The electrochemical cell is driven by the circuits associated with the experiment.

# Cells

Electrochemical cells consist of electrodes immersed in an electrolyte solution connected to an electronic instrument.

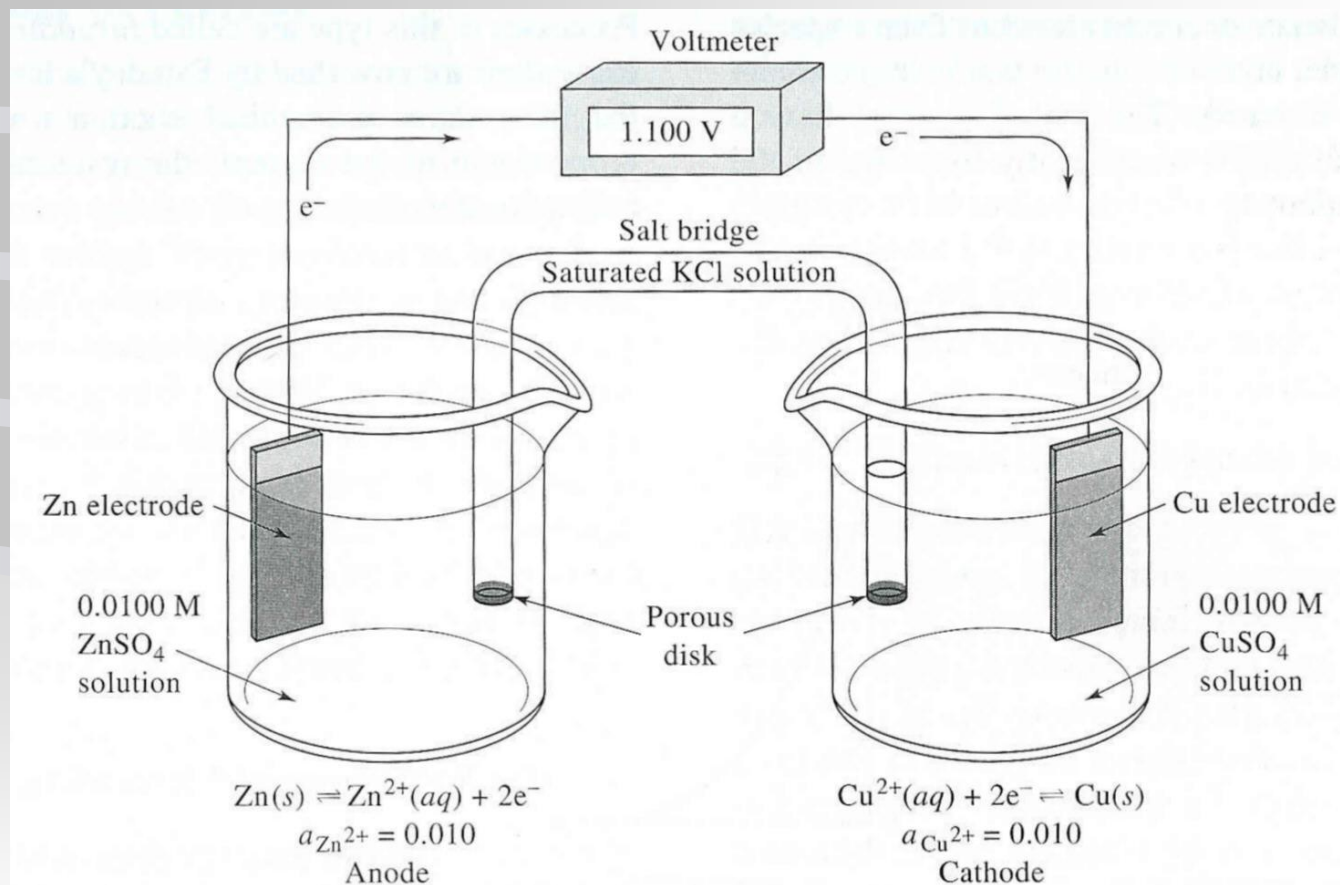

Figure 22-1 A galvanic electrochemical cell with a salt bridge.

# Electrical Concepts

In electrochemical instrumentation, the cell is a circuit element with electrical properties that influence the performance of the overall instrument.

(Unlike spectroscopy – where the cell is quite passive because the phenomena of interest are homogeneous throughout the medium.)

# Electrical Concepts

**Circuit – a closed path that may be followed by an electric current.**

**Series Circuit – all circuit elements are connected in sequence along a unique path.**

**Parallel Circuit - the voltage across each of the components is the same, and the total current is the sum of the currents through each component.**

# Electrical Components

## Components in a Circuit

Symbols are used to represent circuit elements

Lines are wires \_\_\_\_\_

Non-connecting wires

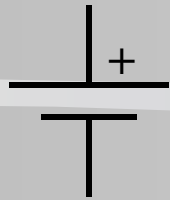

Battery



Resistor

○ External connection

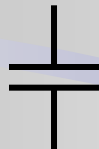

Capacitor



Diode



Potentiometer

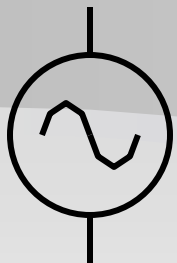

AC voltage source



Inductor

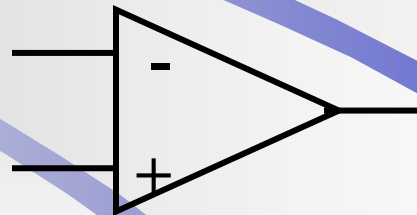

Op amp



Potentiometer  
2-inputs plus  
center tap



Ground

# Electrical Concepts

## Voltage

A battery (Voltage Source) has a positive terminal (+) and a negative terminal (-).

The difference in charge between each terminal is the potential energy the battery can provide. This is labeled in units of volts.

The volt is a measure of the amount of work or energy needed to move an electric charge.

The metric unit of work or energy is the joule (J). One joule = 0.7376 ft · lbs.

The potential difference (or voltage) between two points equals 1 volt when 1 J of energy is expended in moving 1 C of charge between those two points.

$$1 \text{ V} = 1 \text{ J} / 1 \text{ C}$$

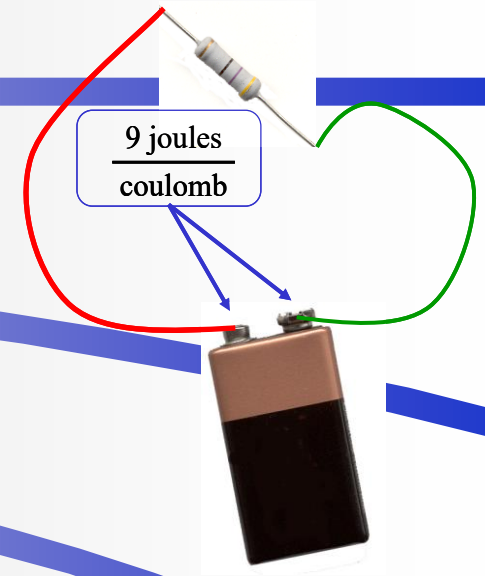

# Electrical Concepts

## Voltage

**V**   **E**

**Potential**

**Voltage = Electro-Motive Force**, the driving force in electron flow

Water Analogy

Electrical Equivalent

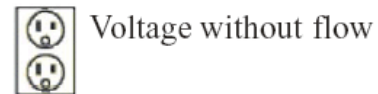
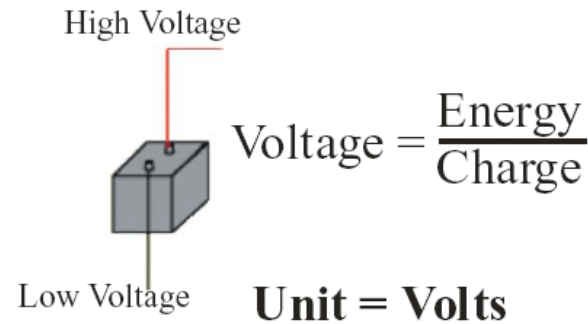
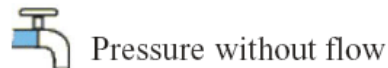
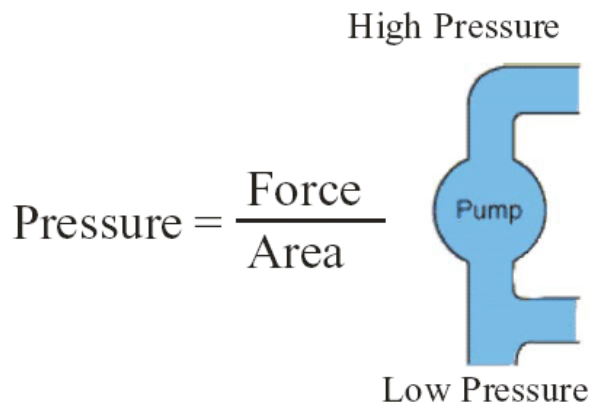

# Electrical Concepts

## Voltage

Voltage is like differential pressure, always measure between two points.

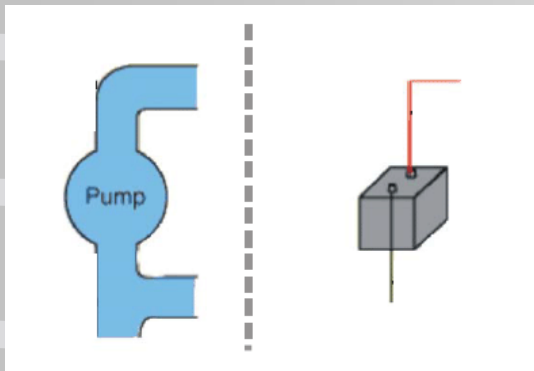

Measure voltage between two points or across a component in a circuit. When measuring DC voltage make sure polarity of meter is correct, positive (+) red, negative (-) black.

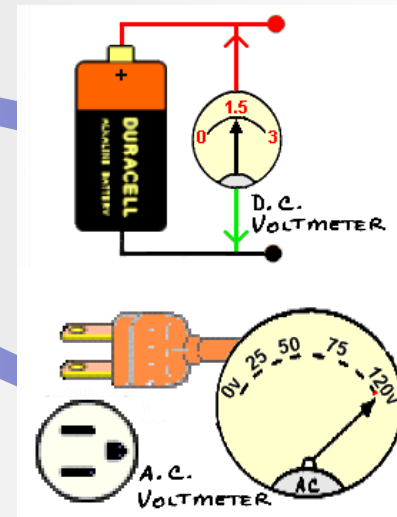

# Electrical Concepts

## Ground

Provides a reference point

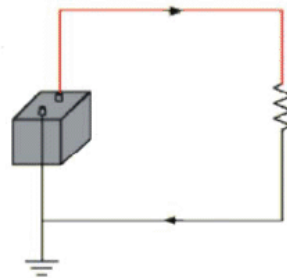
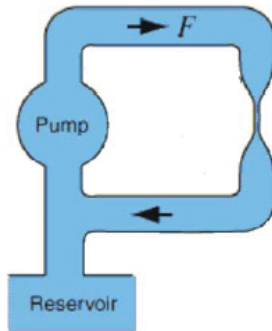

Purely a reference point

Does not participate in current flow

An integral path in the current flow

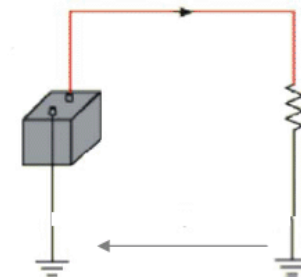
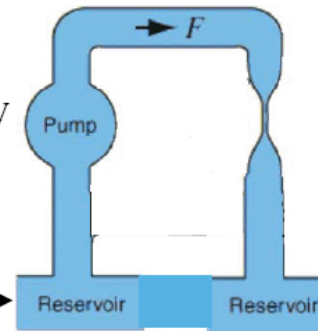

Symbols



Earth

Analog Gnd

# Electrical Concepts

## Current

When the potential difference between two charges causes a third charge to move, the charge in motion is an electric current. The amount of current is dependent on the amount of voltage applied.

Uniform flow of electrons thru a circuit is called *current*.

Current can be defined as the rate of flow of electric charge.

The unit of measure for electric current is the ampere (A).

1 A =  $6.25 \times 10^{18}$  electrons (1C) flowing past a given point each second,  
or 1A= 1C/s.

The letter symbol for current is I or i.

# Electrical Concepts

## Current

Uniform flow of electrons thru a circuit is called *current*.

To measure current, must break circuit and install meter in line.

Measurement is imperfect because of voltage drop created by meter.

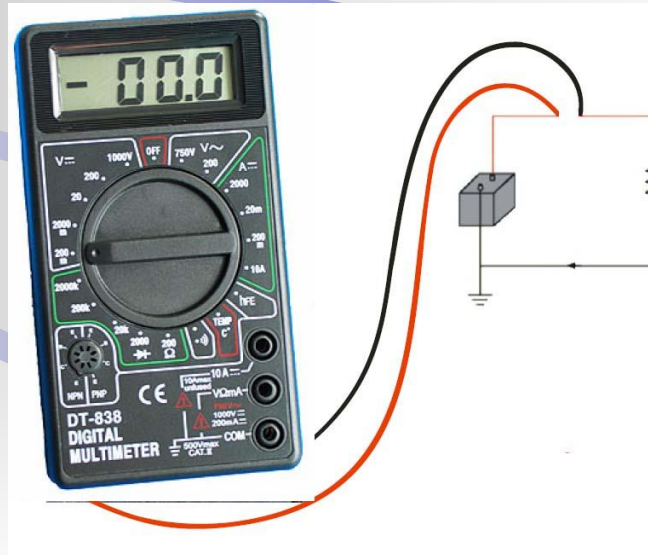

# Electrical Concepts

## Resistance

The measure of opposition to the passage of a steady electric current.

The unit of resistance is the ohm ( $\Omega$ ). The symbol for resistance is R.

Constriction  
creates  
Resistance to water flow

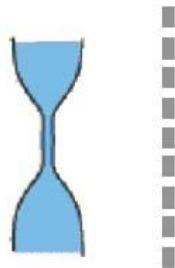

Resistor creates  
Resistance to current  
flow

All materials have a resistance that is dependent on cross-sectional area, material type and temperature.

A resistor dissipates power in the form of heat.



# Electrical Concepts

## Resistors

The two main characteristics of a resistor are its resistance,  $R$ , in ohms and its power rating,  $P$ , in Watts.

The resistance,  $R$ , provides the required reduction in current or the desired drop in voltage.

The wattage rating indicates the amount of power the resistor can safely dissipate as heat. The wattage rating is always more than the actual amount of power dissipated by the resistor, as a safety factor.

# Electrical Concepts

## Types of Resistors

Wire-wound resistors

Carbon-composition resistors

Film-type resistors

    Carbon film

    Metal film

Surface-mount resistors (chip resistors)

Fusible resistors

Thermistors

# Electrical Concepts

## Types of Resistors

### Wire-wound resistors

- Special **resistance wire** is wrapped around an insulating core, typically porcelain, cement, or pressed paper.
- These resistors are typically used for high-current applications with low resistance and appreciable power.



# Electrical Concepts

## Types of Resistors

### Carbon-composition resistors

- Made of carbon or graphite mixed with a powdered insulating material.
- Metal caps with tinned copper wire (called **axial leads**) are joined to the ends of the carbon resistance element.
- Becoming obsolete because of the development of carbon-film resistors.

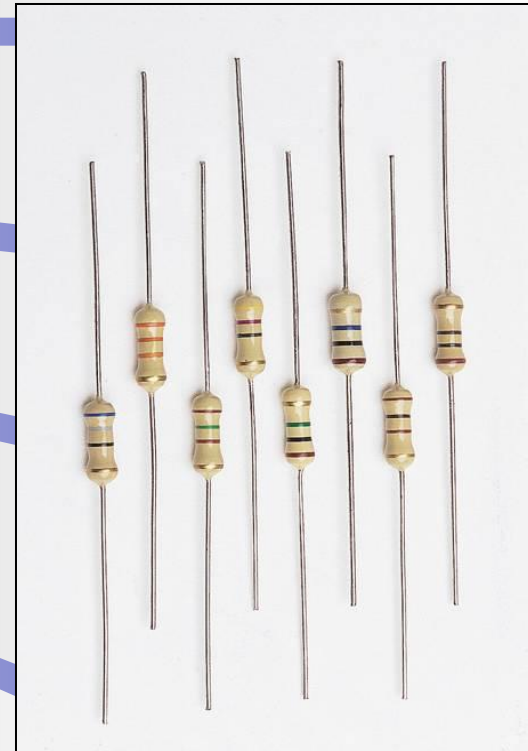

# Electrical Concepts

## Types of Resistors

### Carbon film

Compared to carbon composition resistors, carbon-film resistors have tighter tolerances, are less sensitive to temperature changes and aging, and generate less noise.

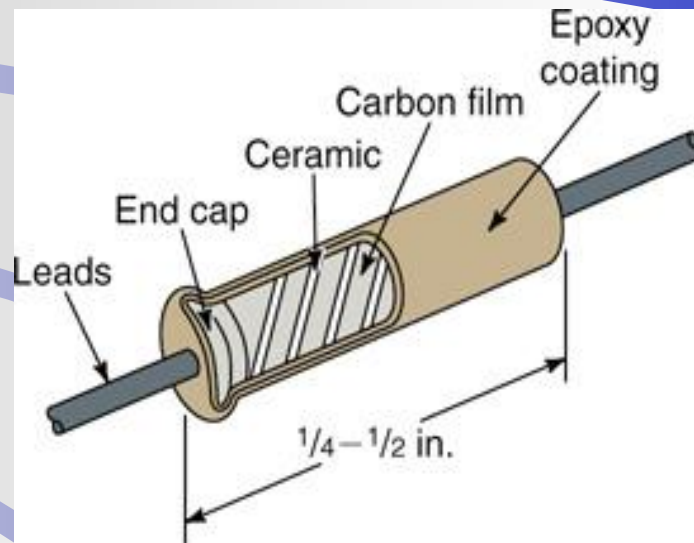

# Electrical Concepts

## Types of Resistors

### Metal film

Metal film resistors have very tight tolerances, are less sensitive to temperature changes and aging, and generate less noise.

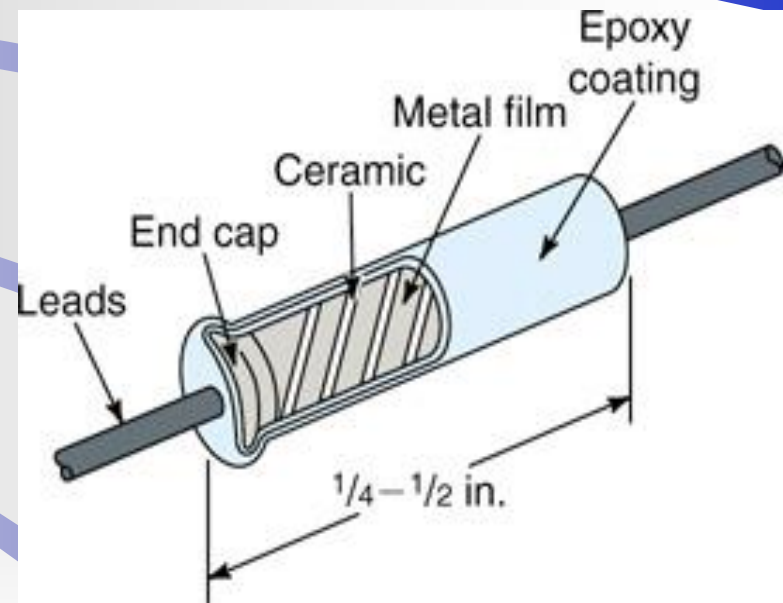
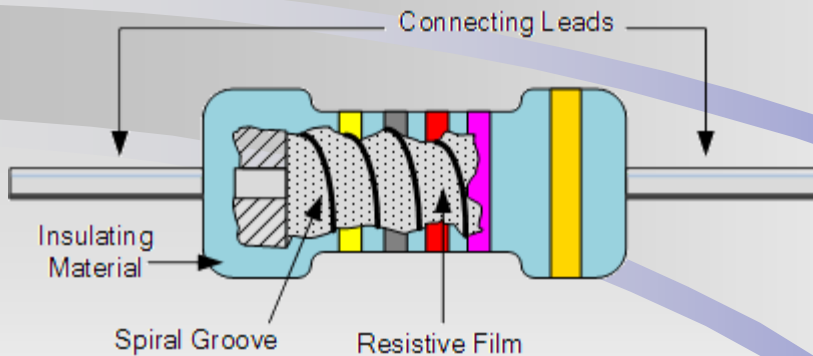

# Electrical Concepts

## Color Code

Color Number

Resistor values determined by color

Three main bands

- 1st = 1st digit
- 2nd = 2nd digit
- 3rd = # of trailing zeros

Examples

- red, brown, black
- 2 1 no zeros = 21 Ohms
- yellow, brown, green
- 4 1 5 = 4.1 Mohm
- purple, gray, orange
- 7 8 3 = 78 kOhms

Capacitors can have 3 numbers

- use like three colors

black 0

brown 1

red 2

orange 3

yellow 4

green 5

blue 6

violet 7

gray 8

white 9

# Electrical Concepts

## Color Code of Resistors

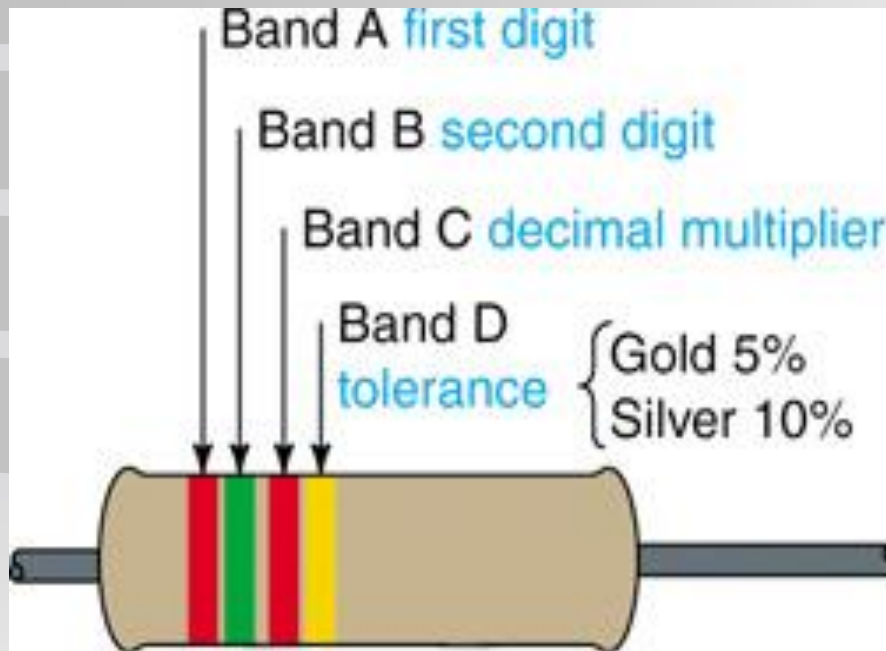

Color Code	
	0 Black
	1 Brown
	2 Red
	3 Orange
	4 Yellow
	5 Green
	6 Blue
	7 Violet
	8 Gray
	9 White

# Electrical Concepts

## Color Code of Resistors

Resistors under  $10\ \Omega$ :

- The multiplier band is either gold or silver.
  - For gold, multiply by 0.1.
  - For silver, multiply by 0.01.

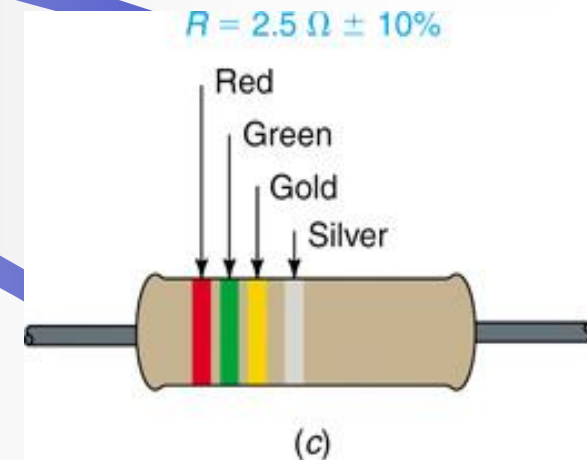
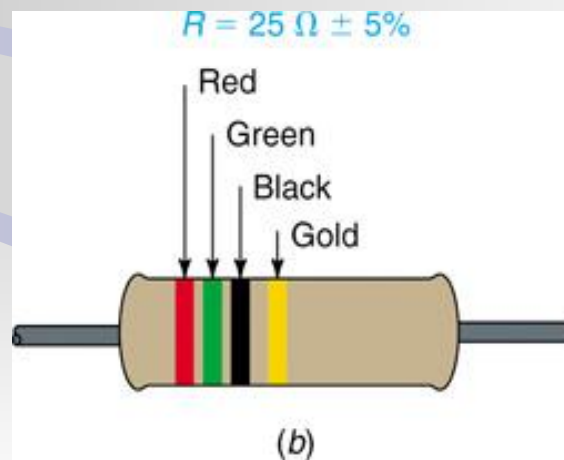
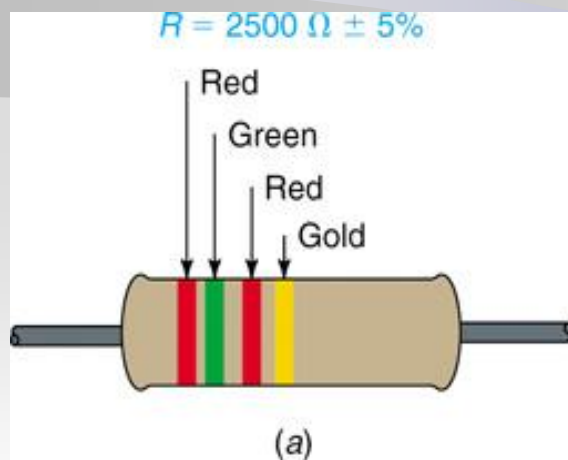

# Electrical Concepts

## Color Code of Resistors

### Five-Band Color Code

- Precision resistors often use a five-band code to obtain more accurate  $R$  values.
- The first three stripes indicate the first 3 digits in the  $R$  value.
- The fourth stripe is the multiplier.
- The tolerance is given by the fifth stripe.
  - Brown = 1%
  - Red = 2%
  - Green = 0.5%
  - Blue = 0.25%
  - Violet = 0.1%.

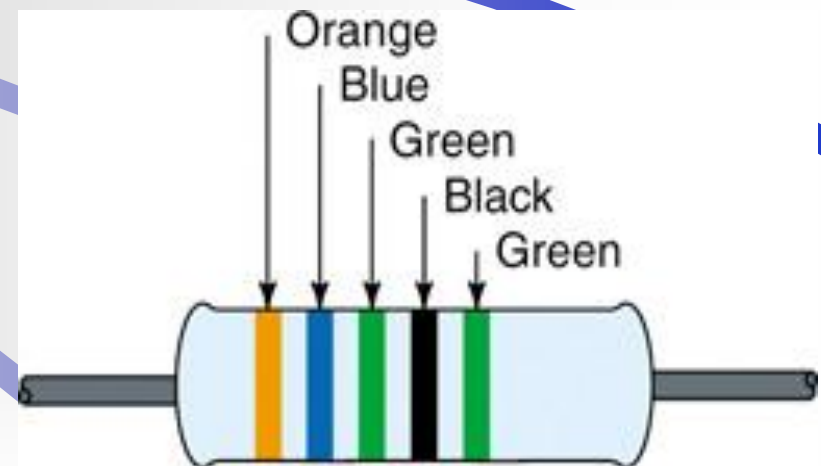

# Electrical Concepts

## Types of Resistors

### Surface-mount resistors (chip resistors)

These resistors are:

- Temperature-stable and rugged
- Their end electrodes are soldered directly to a circuit board.
- Much smaller than conventional resistors with axial leads.



# Electrical Concepts

## Types of Resistors

### Thermistors

Thermistors are temperature-sensitive resistors whose resistance value changes with changes in operating temperature.

Used in electronic circuits where temperature measurement, control, and compensation are desired.

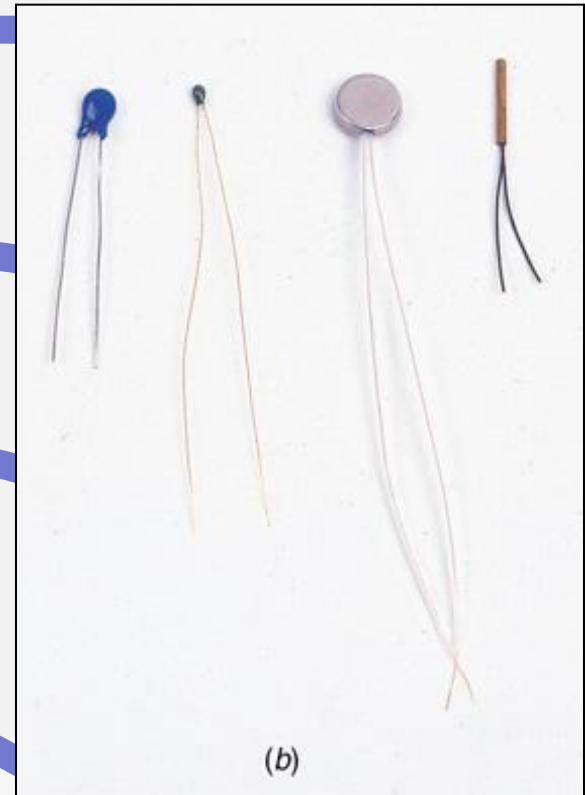

# Electrical Concepts

## Capacitance

The measure of the amount of electrical energy stored (or separated) for a given electric potential.

A capacitor is used to store charge for a short amount of time.

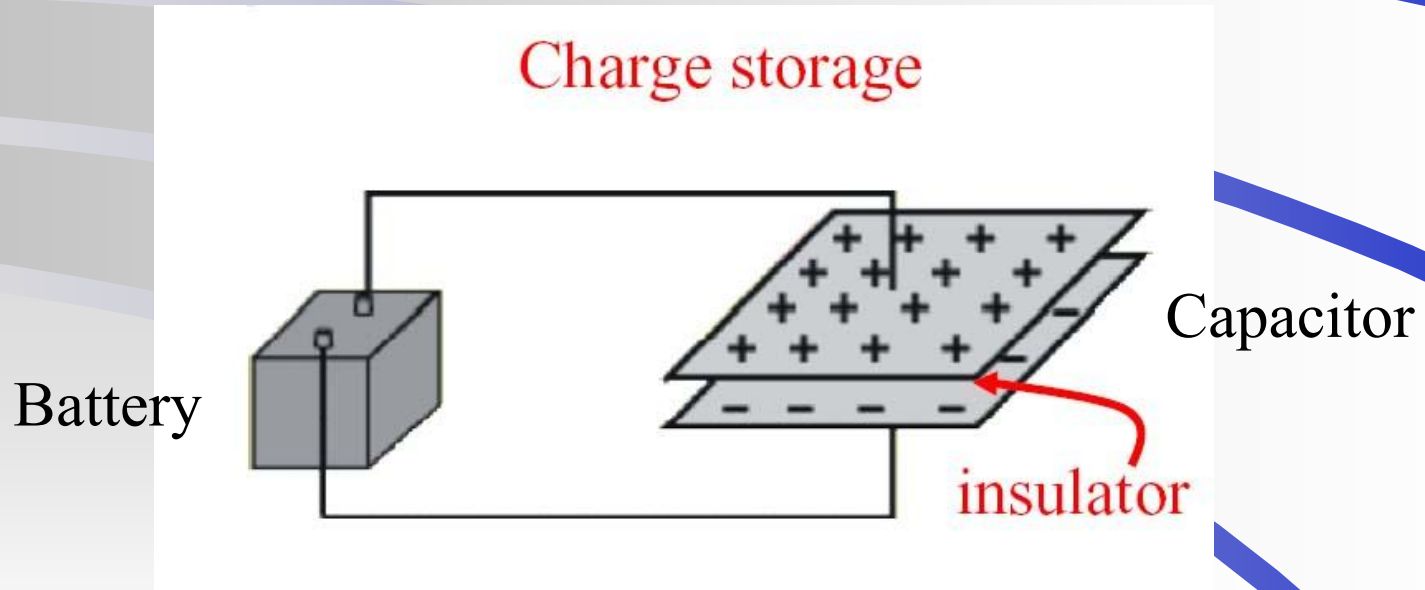

# Electrical Concepts

## Inductance

The property in an electrical circuit where a change in the electric current through that circuit induces an electromotive force (EMF) that opposes the change in current.

Inductor is simply a coil of wire. (electromagnet)

# Electrical Concepts

## Inductance

### Water Analogy

- Imagine a narrow channel with water flowing through it, and a heavy water wheel that has its paddles dipping into the channel. If the water in the channel is not flowing initially, you try to start the water flowing.

The paddle wheel will tend to prevent the water from flowing until it has come up to speed with the water.

If you then try to stop the flow of water in the channel, the spinning water wheel will try to keep the water moving until its speed of rotation slows back down to the speed of the water.

An inductor is doing the same thing with the flow of electrons in a wire -- **an inductor resists a change in the flow of electrons.**

# Electrical Concepts

## Impedance

A measure of opposition to alternating current (AC), describes not only the relative amplitudes of voltage and current, but also relative phases.

When a circuit is driven with direct current (DC), there is no distinction between impedance and resistance (can be thought of as impedance with zero phase angle).

# Electrical Concepts

## Laws of Electricity

### Ohm's Law

Describes the relationship between voltage, resistance, and current in a resistive series circuit.

$$V=IR$$

V- potential difference in volts between two points in a circuit

R – resistance between the two points in ohms

I – resulting current in amperes

# Electrical Concepts

## Laws of Electricity

### Kirchhoff's Law

The algebraic sum of currents at any point in a circuit is zero.

The algebraic sum of the voltages around a closed conducting path or loop is zero.

# Electrical Concepts

## Laws of Electricity

### Kirchhoff's Law

The circuit has 3 branches,  
2 nodes (A and B) and 2  
independent loops.

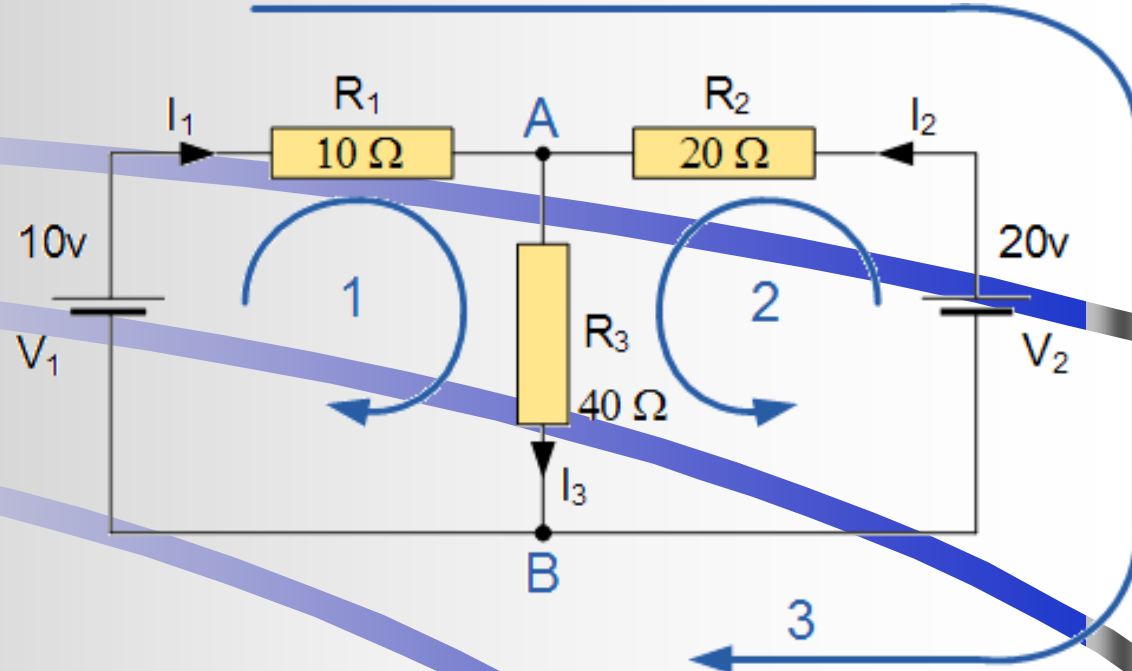

At node A :  $I_1 + I_2 = I_3$

At node B :  $I_3 = I_1 + I_2$

Loop 1 is given as :  $10 = R_1 I_1 + R_3 I_3 = 10I_1 + 40I_3$

Loop 2 is given as :  $20 = R_2 I_2 + R_3 I_3 = 20I_2 + 40I_3$

# Electrical Concepts

## Laws of Electricity

### Power Law

Power (in watts) dissipates in a resistive element by the product of the current and potential difference across the element in volts.

$$P = IV$$

$$P = I^2R = V^2/R$$

# Electrical Concepts

**A circuit can be defined as a path for current flow.**

**Any circuit has three key characteristics:**

- 1. There must be a source of potential difference (voltage). Without voltage - current cannot flow.**
- 2. There must be a complete path for current flow.**
- 3. The current path normally has resistance, either to generate heat or limit the amount of current.**

# Electrical Concepts

## Types of Circuits

When a current path is broken (incomplete) the circuit is said to be open.

The resistance of an open circuit is infinitely high. There is no current in an open circuit.

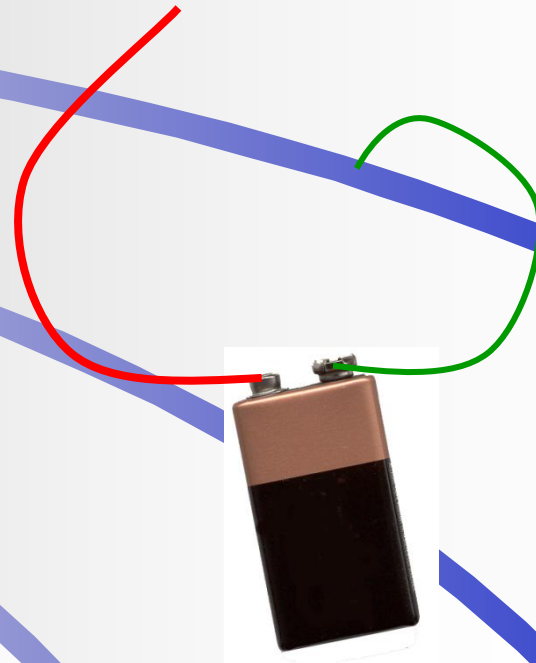

# Electrical Concepts

## Types of Circuits

When the current path is closed but has little or no resistance, the result is a short. Short circuits can result in too much current.

When the current path is closed but has resistance, the result is a closed.

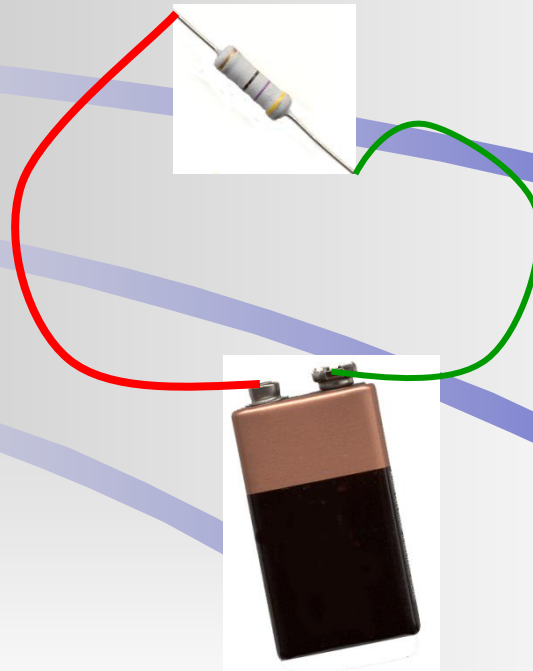

# Electrical Concepts

## Series Circuits

### Basic series circuit

-battery

-switch

-resistors

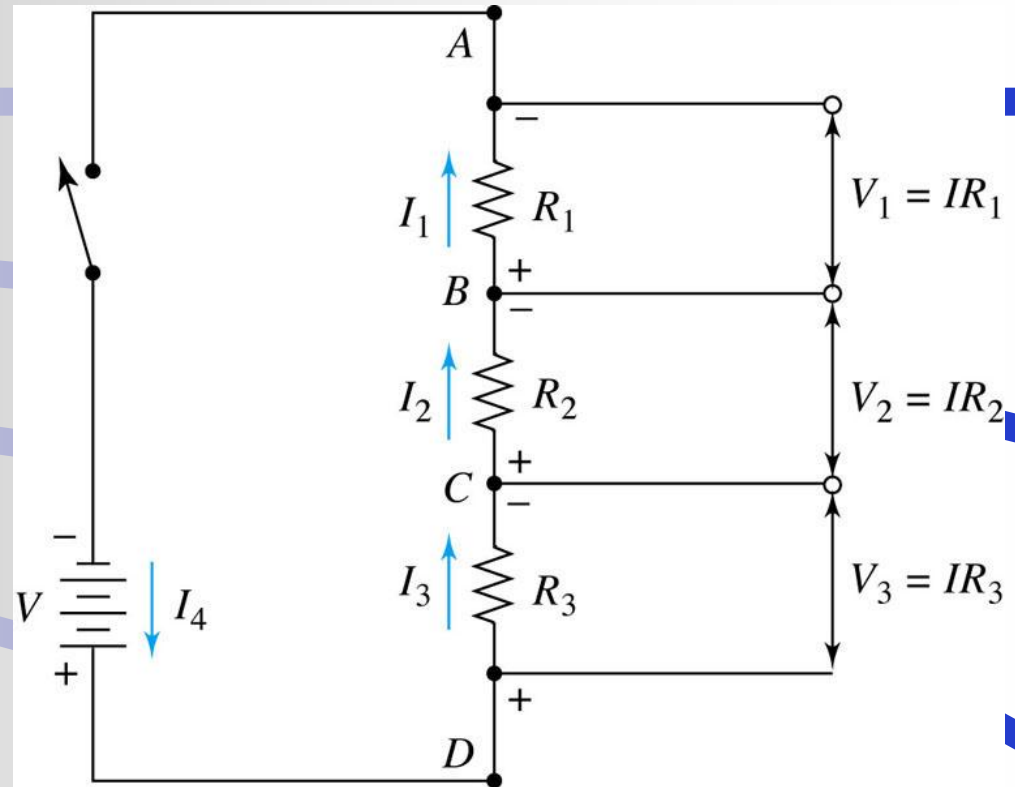

$$I = I_1 = I_2 = I_3 = I_4$$

$$V = V_1 + V_2 + V_3$$

$$R = R_1 + R_2 + R_3$$

© 2007 Thomson Higher Education

# Electrical Concepts

## Series Circuits

Close switch – current flows.

At point D:

$$I_4 - I_3 = 0 \text{ (Kirchoff's law)}$$

$$I_4 = I_3$$

The current is the same at all points in a series circuit.

$$I = I_1 = I_2 = I_3 = I_4$$

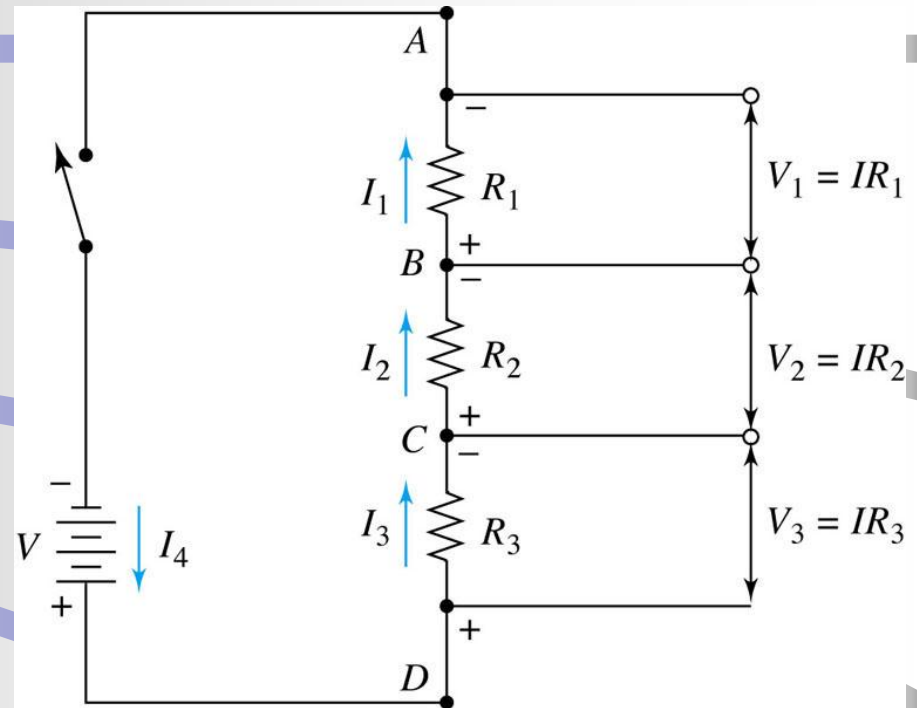

$$I = I_1 = I_2 = I_3 = I_4$$

$$V = V_1 + V_2 + V_3$$

$$R = R_1 + R_2 + R_3$$

© 2007 Thomson Higher Education

# Electrical Concepts

## Series Circuits

Applying Kirchhoff's Law  
to voltage:

$$V - V_3 - V_2 - V_1 = 0$$

$$V = V_3 + V_2 + V_1$$

The voltage increase,  $V$ , is  
followed by 3 voltage decreases

$V_3$ ,  $V_2$ , and  $V_1$  (a voltage drop across each resistor)

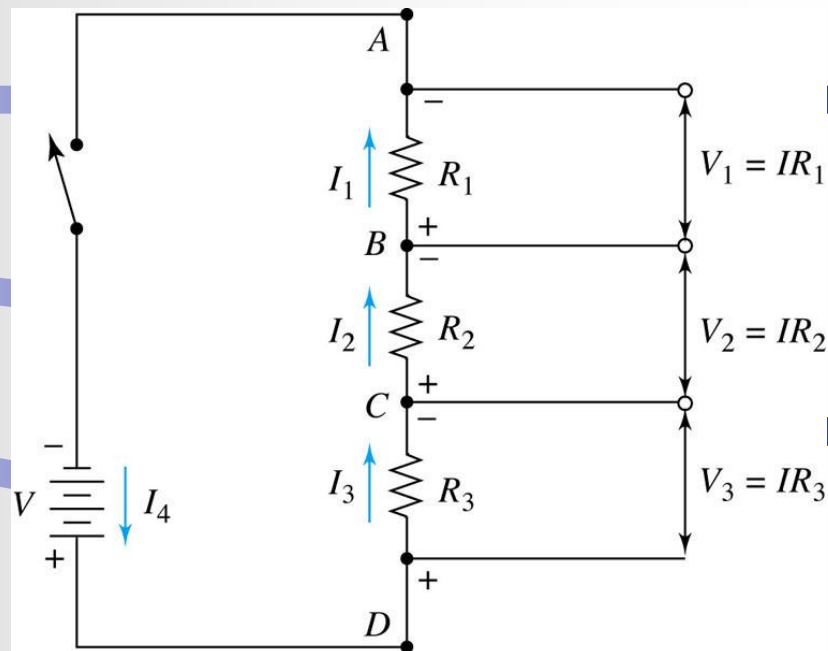

$$I = I_1 = I_2 = I_3 = I_4$$

$$V = V_1 + V_2 + V_3$$

$$R = R_1 + R_2 + R_3$$

© 2007 Thomson Higher Education

# Electrical Concepts

## Voltage Divider

**Resistors in a series form a voltage divider so that a fraction of the total voltage appears across each resistor.**

**Voltage dividers are used in electrical circuits to provide output voltages that are a fraction of an input voltage.**

# Electrical Concepts

## Voltage Divider

Voltage dividers in circuits are attenuators or rheostats or potentiometers.

**Attenuators** – use fix series resistors to provide voltages in fixed increments.

**Potentiometers** – the resistance is linear – the resistance at a point is proportional to the length.

# Electrical Concepts

## Attenuator

For the switch position, the voltage drop across 2 resistors ( $100\ \Omega$  and  $100\ \Omega$ ) is the output voltage  $V$ .

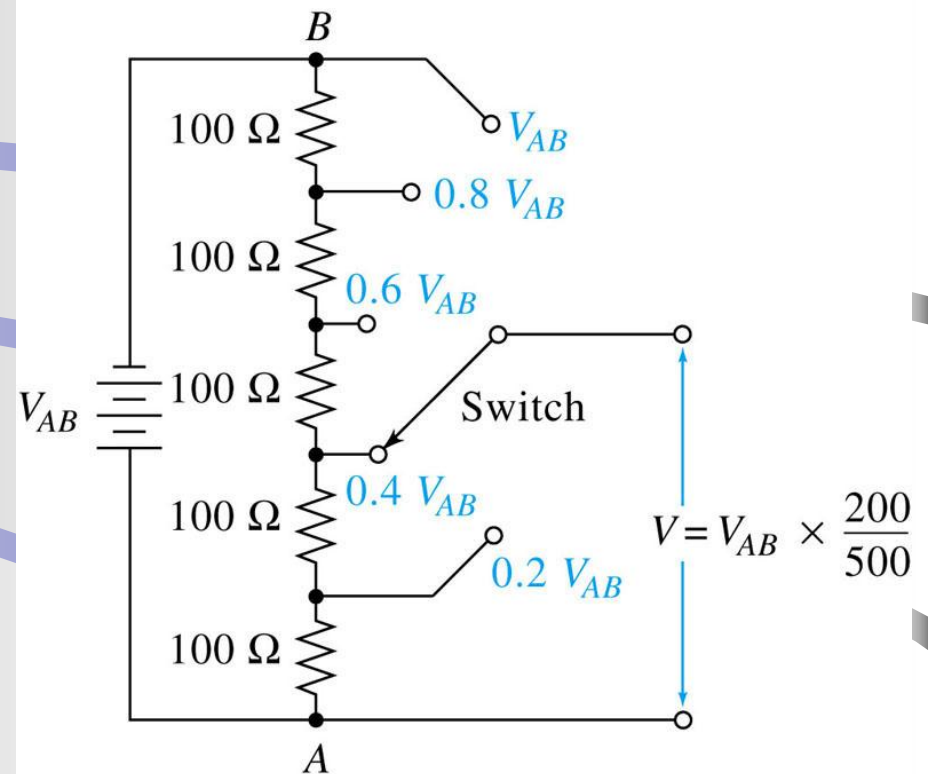

(a)

# Electrical Concepts

## Potentiometers or Rheostats

Use variable resistors

**A variable resistor is a resistor whose resistance value can be changed.**

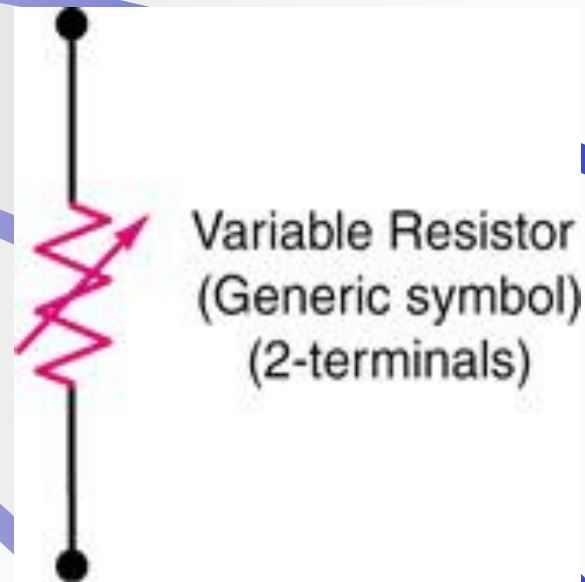

# Electrical Concepts

## Rheostats

- Two terminals.
- Connected in series with the load and the voltage source.
- Varies the current.

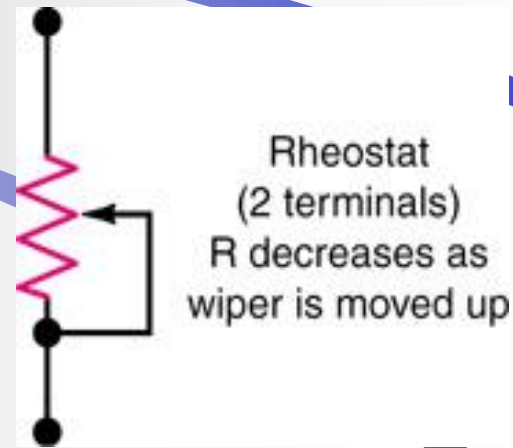
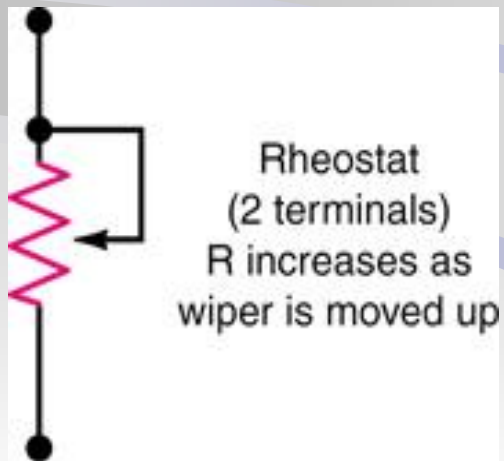

# Electrical Concepts

## Potentiometer

Provides a voltage that is continuously variable from 0 V to full input voltage,  $V_{AB}$ .

Resistance between A and C is proportional to the length, AC.

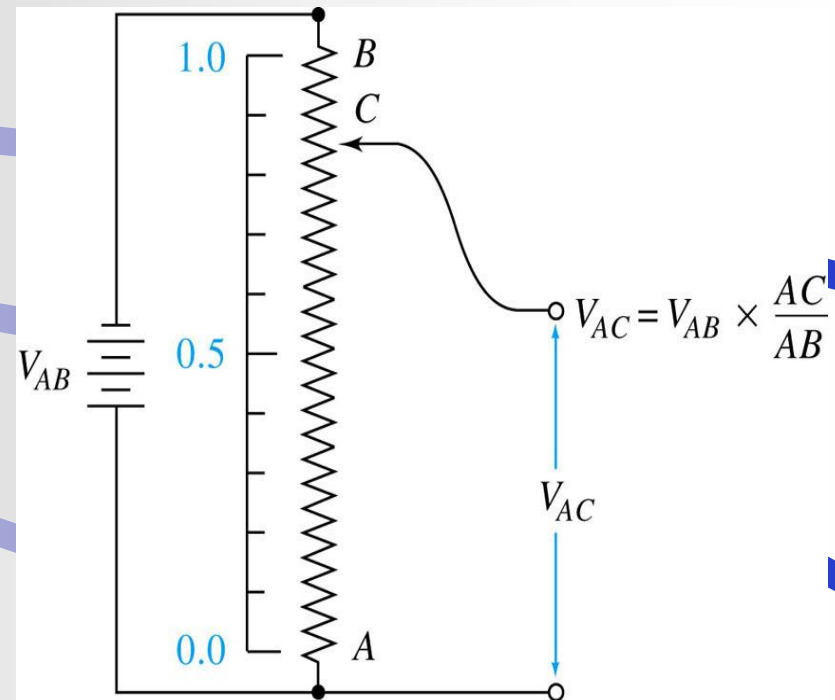

(b)

© 2007 Thomson Higher Education

# Electrical Concepts

## Parallel Circuits

Voltage is the same across each branch in a parallel circuit.

The total current is equal to the sum of the individual branch currents.

This is known as Kirchhoff's current law.

It applies to any number of parallel branches, whether the resistances in those branches are equal or not.

# Electrical Concepts

## Parallel Circuits

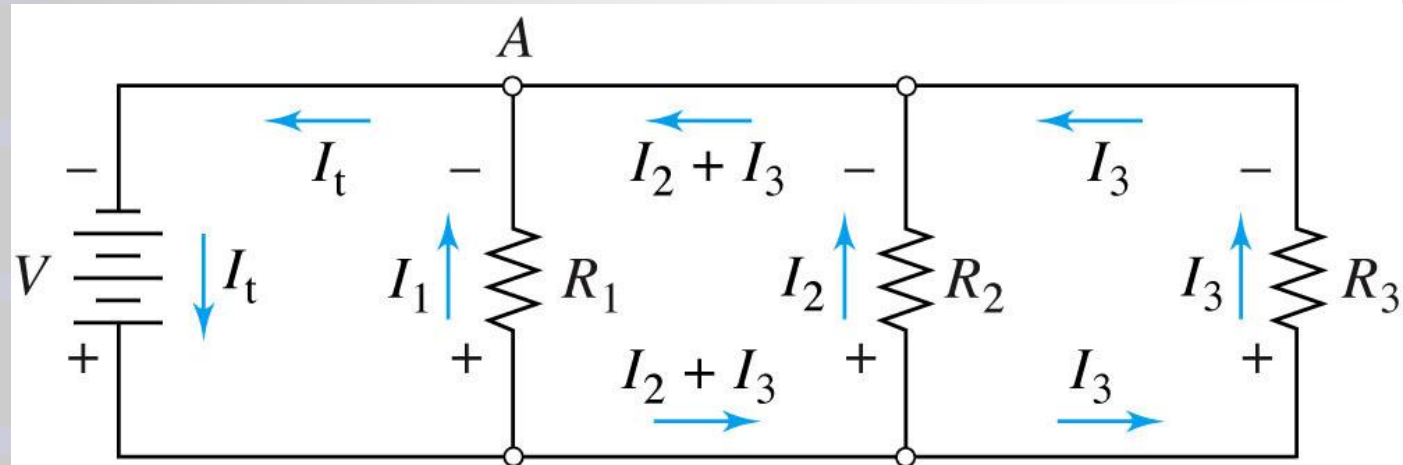

© 2007 Thomson Higher Education

**Applying Kirchhoff's Law to current:**

at point A,  $I_1 + I_2 + I_3 - I_t = 0$  or  $I_t = I_1 + I_2 + I_3$

**Applying Kirchhoff's Law to voltage:**

$V = I_1R_1$  and  $V = I_2R_2$  and  $V = I_3R_3$

**The battery voltage appears across all three resistors.**

# Electrical Concepts

## Parallel Circuits

Parallel circuits create a current divider or current splitter.

# Electrical Concepts

Current, voltage, and resistance measurements are done by Digital Voltmeters (DVM) and Multimeters (DMM).



# Electrical Concepts

## Digital Voltmeters (DVM) and Multimeters (DMM).

**DVM consist of a single integrated circuit, a power supply, and liquid crystal display.**

**The integrated circuit is an analog-to-digital converter.**

**The DVM is part of the DMM which can measure current and resistance as well as voltage.**

# Class Assignment

- Research paper Topic
- Read Chapter 1, 4, and 13

“Electrochemical Methods” Bard

