

chem 5390

Advanced X-ray Analysis



LECTURE 3

Dr. Teresa D. Golden
University of North Texas
Department of Chemistry

Production and Properties of X-rays

A. Production of X-rays

1. Origins of X-rays

Produced when fast moving electrons impinge on matter. Electrons are decelerated and x-rays are produced by two general types of interactions.

Production and Properties of X-rays

A. Production of X-rays

a. Ionization of an atom

High speed electrons strike and displace a tightly bound electron deep in an atom near the nucleus. Electrons from an outer shell decays and fills the vacant place by emitting an x-ray. These x-rays are characteristic of the atom (Quantum process).

Production and Properties of X-rays

A. Production of X-rays

b. Decrease of energy

High speed electron slowed down by passing through a strong electric field near the nucleus of the atom. Decrease in energy, ΔE .

These x-rays are independent of the atom and appear as a continuous band of wavelengths. The lower limit is a function of the maximum energy of bombarding electrons λ_{SWL} (the short wave limit).

Intensity (relative units)

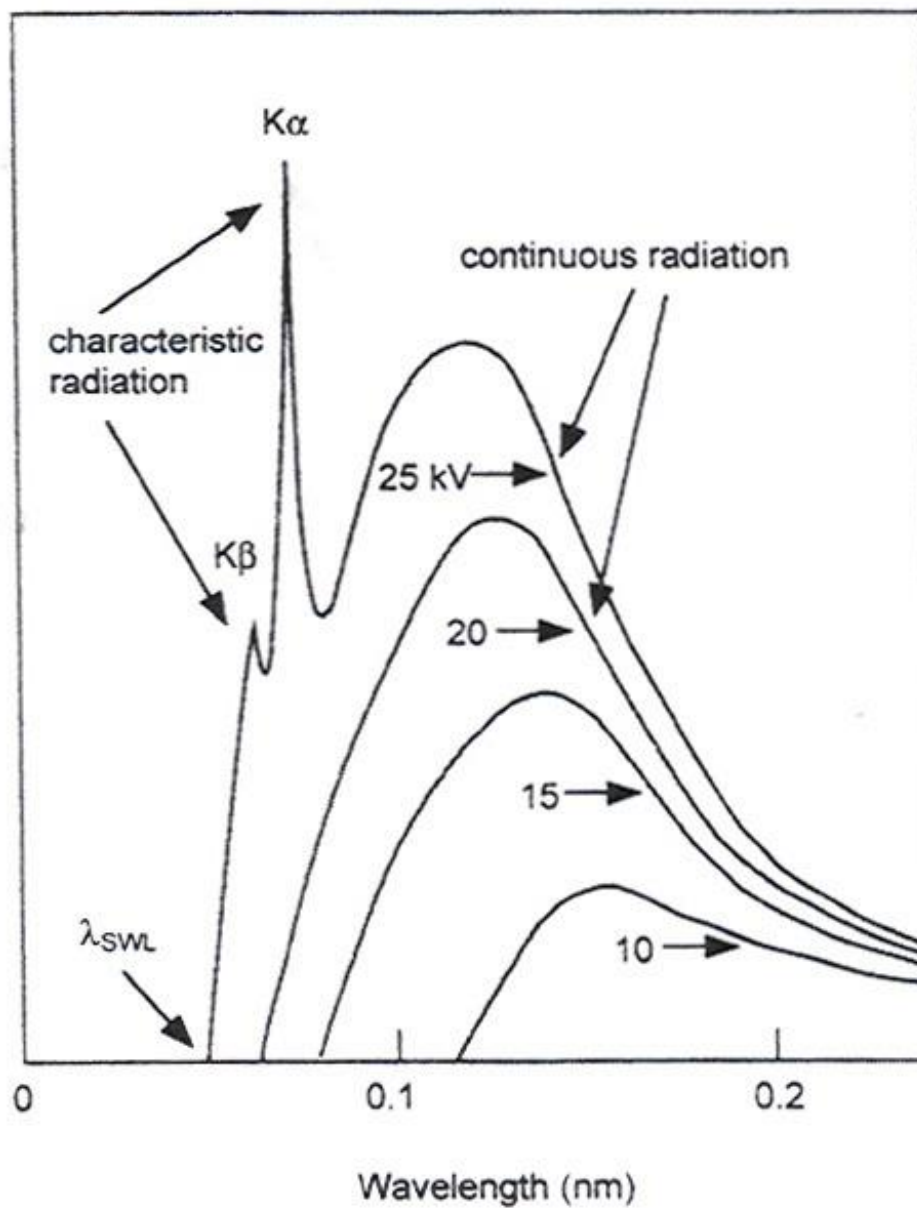

Production and Properties of X-rays

A. Production of X-rays

2. X-ray tubes

Used to Generate the x-rays

a. Gas tubes - original tubes used by Roentgen (not used anymore).

Production and Properties of X-rays

A. Production of X-rays

2. X-ray tubes

b. Filament tubes

Invented by Coolidge in 1913.

Hot-Cathode tube - tube is evacuated (in a vacuum).

Electrons are supplied by a heated filament (W), called the cathode. Filament requires $i = 1.5$ to 5 A and 4 to 12 V to incandescence. Filament temperature ranges from 1800 to 2600 °C. The cathode is held at a high negative potential.

Production and Properties of X-rays

A. Production of X-rays

2. X-ray tubes

b. Filament tubes

The electrons produced at the cathode are accelerated toward the anode, which is held at ground. Electrons strike the target (anode) at a high velocity.

X-rays are produced and radiate in all directions. (~1% of the electron beam is converted to x-rays).

Production and Properties of X-rays

A. Production of X-rays

2. X-ray tubes

b. Filament tubes

At a tube voltage of 30KV (30,000 Volts), the velocity of the electrons is $\sim 1/3$ the speed of light.

KE - kinetic energy of electrons = $eV = 1/2mv^2$

KE – joules

e - charge of electron (1.60×10^{-19} coulombs)

V - voltage across the electrodes (accelerating voltage)

m - mass of electron (9.11×10^{-31} kg)

v - velocity (m/s).

Production and Properties of X-rays

A. Production of X-rays

2. X-ray tubes

b. Filament tubes

At high voltages, the current, i , is a function of the number of thermal electrons, which is controlled by the temperature of the filament.

Filament tube

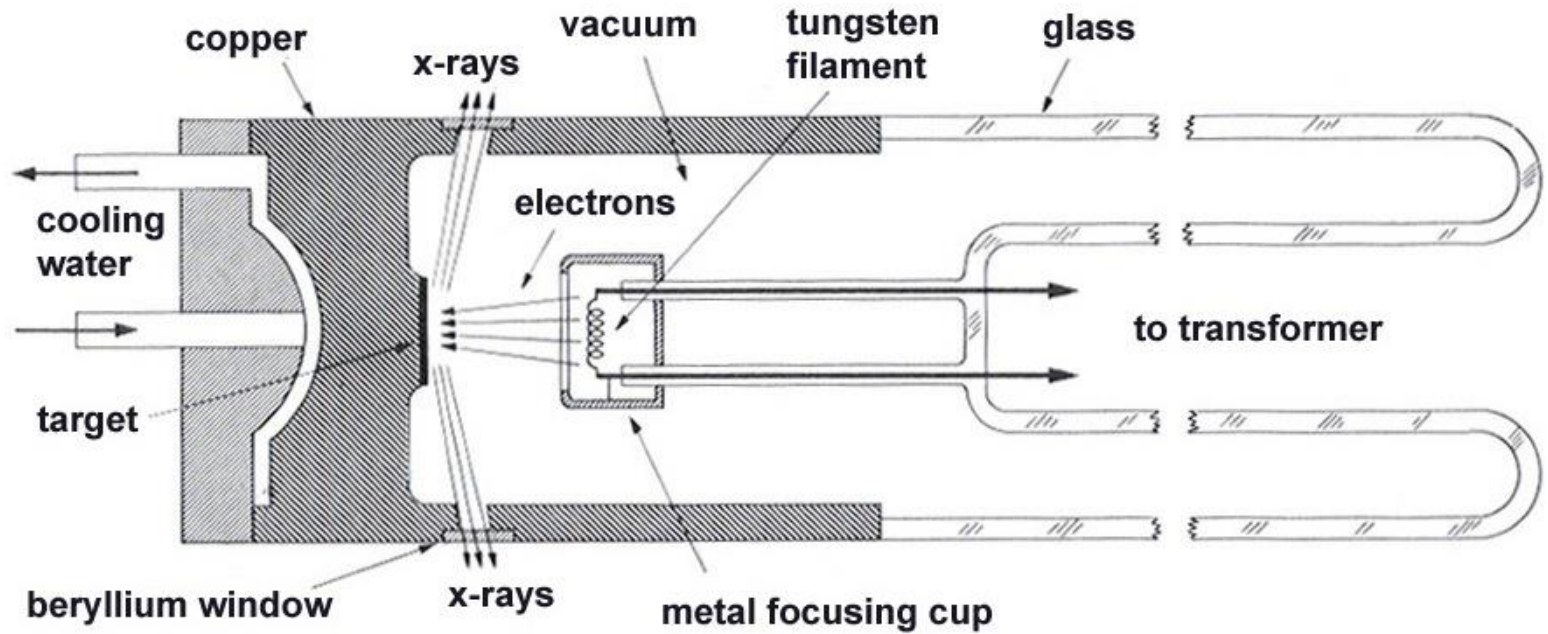

Production and Properties of X-rays

A. Production of X-rays

b. Filament tubes

Failure of these tubes due to:

- 1) sudden outburst of traces of occluded gases (results in passage of large currents).
 - 2) Puncture resulting from accidentally exceeding the voltage limit.
 - 3) Tungsten (W) vaporization from the filament (eventually filament becomes thin and breaks).
- ~2000 hours of service at highest settings.

This also results in deposition of W on the surface of the target (contamination).

Production and Properties of X-rays

A. Production of X-rays

b. Filament tubes

Companies have tried to solve tube problems by:

- 1) increasing intensity of x-rays.
- 2) minimize absorption of beam by tube windows.
- 3) avoid contamination radiation (W on target).
- 4) make tubes shockproof and x-rayproof.

Production and Properties of X-rays

A. Production of X-rays

b. Filament tubes

1) increasing intensity of x-rays:

- use focal spot, electron beam brought to a line focus instead of point focus (1.2 mm width x 12 mm length).
- cooling of target to prevent loss of energy through generation of heat.
- greater energy obtained by oscillating or rotating targets (constantly changes cooled face).

Production and Properties of X-rays

A. Production of X-rays

2. X-ray tubes

b. Filament tubes

2) minimize absorption of beam by tube windows.

- Done by using transparent windows (especially for Cu). These windows composed of low atomic number elements, i.e:

Lindemann glass - B, Li, Be (not used anymore).

Mica window - 0.0005 in. thick backed by thin Be foil (used today).

Be window - thin Be sheets with 0.2% Ti (used today).

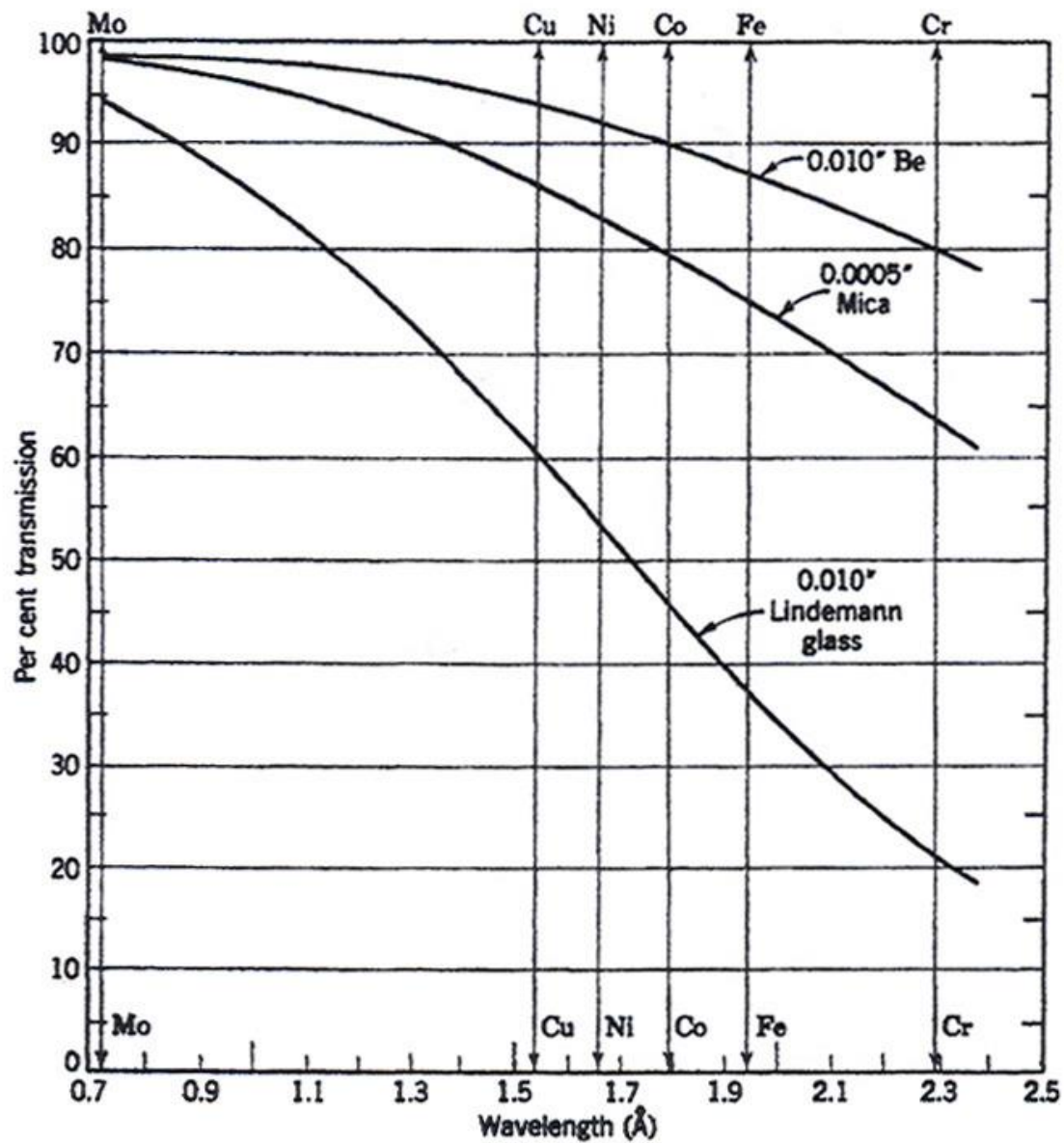

Make	Number of Windows	Window Material	Focal Spot (mm)	Filament Current (A)	Filament Voltage (V)	Maximum Voltage (peak kV)	Maximum Current at Maximum Voltage (mA)	Cooling Water
DZ-1B, Dunlee-Picker	Four (two spot foci, two line foci)	Be	0.75 × 15.0	2.1-2.9	3.2-8.5	50	Mo, 22 Cu, 20 Fe, 10 Cr, 16	5 pt/min
Y613-618 series, Enraf-Nonius	Four (two spot foci, two line foci)	Mica-Be	1 × 10	2.8-3.8	6.5-11.0	50	Mo, 24 Cu, 24 Fe, 10 Cr, 8	3.5 l/min
CA-8S, General Electric	Three (two spot foci, one line focus)	Be	0.8 × 12.5	2.5-4.5	3.0-9.0	50	Mo, 25 Cu, 20 Fe, 10 Cr, 16	8 pt/min
Type 140-00X-00, Norelco	Four (two spot foci, two line foci)	Mica-Be	1 × 10	3.3-3.7	6.9	60	Mo, 29 Cu, 29 Fe, 19 Cr, 29	3 qt/min
Type A Gq-3Ö, Siemens	Three (two spot foci, one line focus)	Be	0.75 × 10	4.1	5.6-7.3	50	Mo, 15 Cu, 15 Fe, 9 Cr, 9	4 l/min
AEG-F50, Syntex	Four (two spot foci, two line foci)	Be	1 × 10	3.8	11.0	60 55 55 55	Mo, 16.5 Cu, 18 Fe, 6.5 Cr, 5.5	3.5 l/min

Production and Properties of X-rays

A. Production of X-rays

2. X-ray tubes

b. Filament tubes

3) avoid contamination radiation (W on target).

- increase anode-cathode distance.

- recess Be window into walls to shield from W vapor.

Production and Properties of X-rays

B. Properties of X-rays

X-rays are part of the electromagnetic spectrum and exhibit a dual nature, behaving as waves and particles.

**Part of the
electromagnetic
spectrum.**

**Note that the
boundaries between
regions are arbitrary.
The usable range of x-
ray wavelengths for x-
ray diffraction studies
is between 0.05 and
0.25 nm (only a small
part of the total range
of x-ray wavelengths).**

$h\nu$ [eV]	ν [Hz]	λ [nm]	Radiation
	10 ¹⁴		infrared
1		10 ³	visible
10	10 ¹⁵	10 ²	ultraviolet
10 ²	10 ¹⁶	10	
10 ³	10 ¹⁷	1	x-rays
10 ⁴	10 ¹⁸	10 ⁻¹	
10 ⁵	10 ¹⁹	10 ⁻²	
10 ⁶	10 ²⁰	10 ⁻³	
10 ⁷	10 ²¹	10 ⁻⁴	γ -rays
10 ⁸	10 ²²	10 ⁻⁵	

Production and Properties of X-rays

B. Properties of X-rays

X-ray spectrum composed of a line spectrum of intense single wavelengths superimposed on a continuous background.

Intensity (relative units)

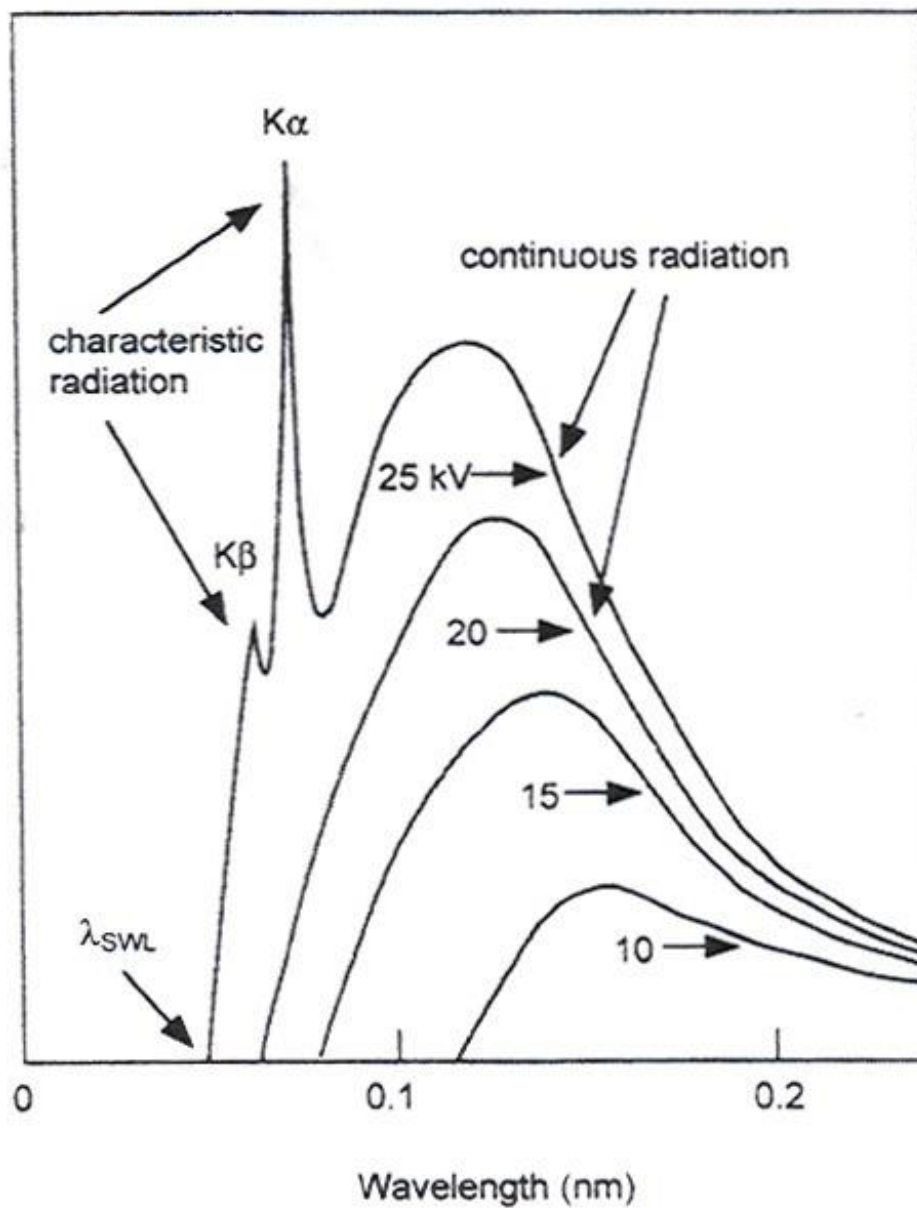

Production and Properties of X-rays

B. Properties of X-rays

1. Continuous X-ray spectrum

Plot of the x-ray intensity at several wavelengths.

The wavelength limits and intensity distribution is dependent on applied voltage.

Production and Properties of X-rays

B. Properties of X-rays

1. Continuous X-ray spectrum

As applied voltage increases, the minimum wavelength (λ_{SWL}) shifts to lower values and the intensity of all wavelengths increase.

The spectrum results from the deceleration of electrons by the electric fields of the target atoms.

Production and Properties of X-rays

B. Properties of X-rays

1. Continuous X-ray spectrum

λ_{SWL} - due to a single encounter of one electron with an atom in which the electron loses all its energy.

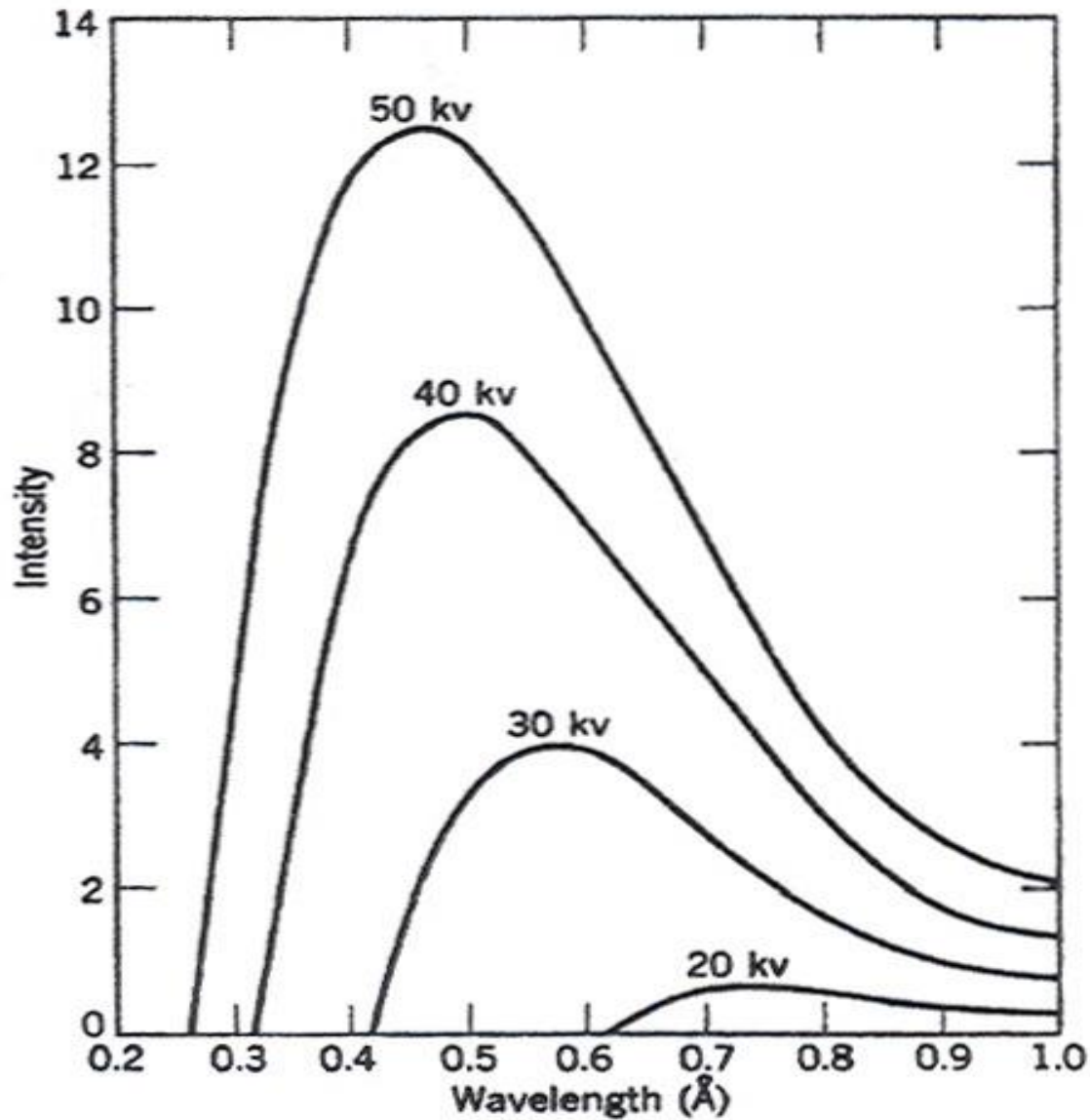

Intensity distribution versus wavelength in the continuous x-ray spectrum of tungsten at several voltages.

Production and Properties of X-rays

B. Properties of X-rays

1. Continuous X-ray spectrum

The energy of the photon released is equal to the energy, E of the electron.

Energy of the fastest moving electron is:

$$E = eV = h\nu \quad \nu = c/\lambda \quad \lambda = hc/eV$$

$$\lambda = (6.626 \times 10^{-34})(2.998 \times 10^8)/(1.602 \times 10^{-19}) V$$

$$\lambda = 12.40 \times 10^3/V \quad (\lambda - \text{units is } \text{\AA})$$

Production and Properties of X-rays

B. Properties of X-rays

1. Continuous X-ray spectrum

Example: At 40 KV

$$\lambda_{\min} = 12.40 \times 10^3 / 40,000 = 0.31 \text{ \AA}$$

The total x-ray energy emitted per second is proportional to the area under the curve and is dependent on the atomic number, Z , of the target and the tube current, i .

Material of the target affects the intensity, but not the wavelength distribution of the continuous spectrum.

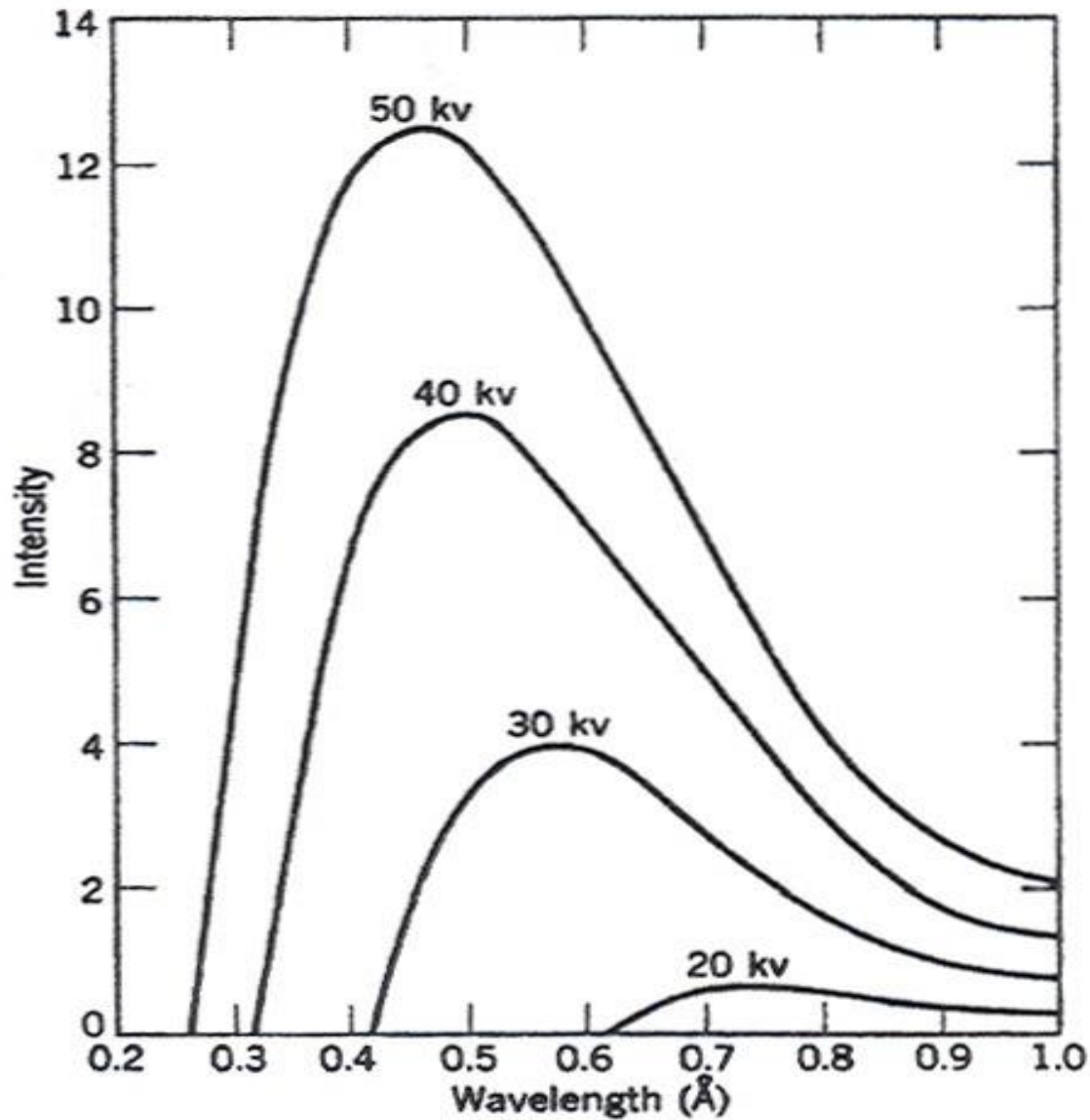

Intensity distribution versus wavelength in the continuous x-ray spectrum of tungsten at several voltages.

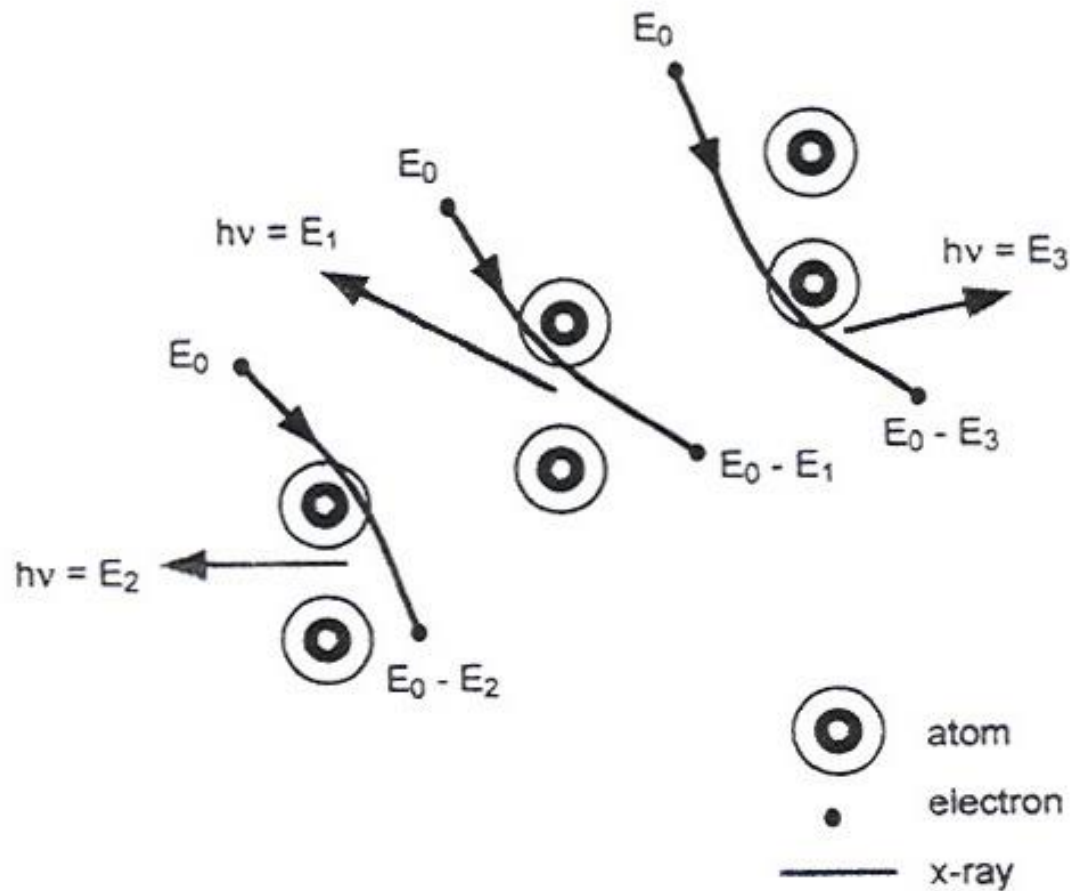

Illustration of the origin of continuous radiation in the x-ray spectrum. Each electron, with initial energy E_0 , loses some, or all, of its energy through collisions with atoms in the target. The energy of the emitted photon is equal to the energy loss in the collision.

Production and Properties of X-rays

B. Properties of X-rays

2. Characteristic X-ray spectrum

Instead of a loss of energy by deceleration, the electrons ionize the target atoms.

The resulting spectrum is characteristic lines superimposed on the continuous spectrum.

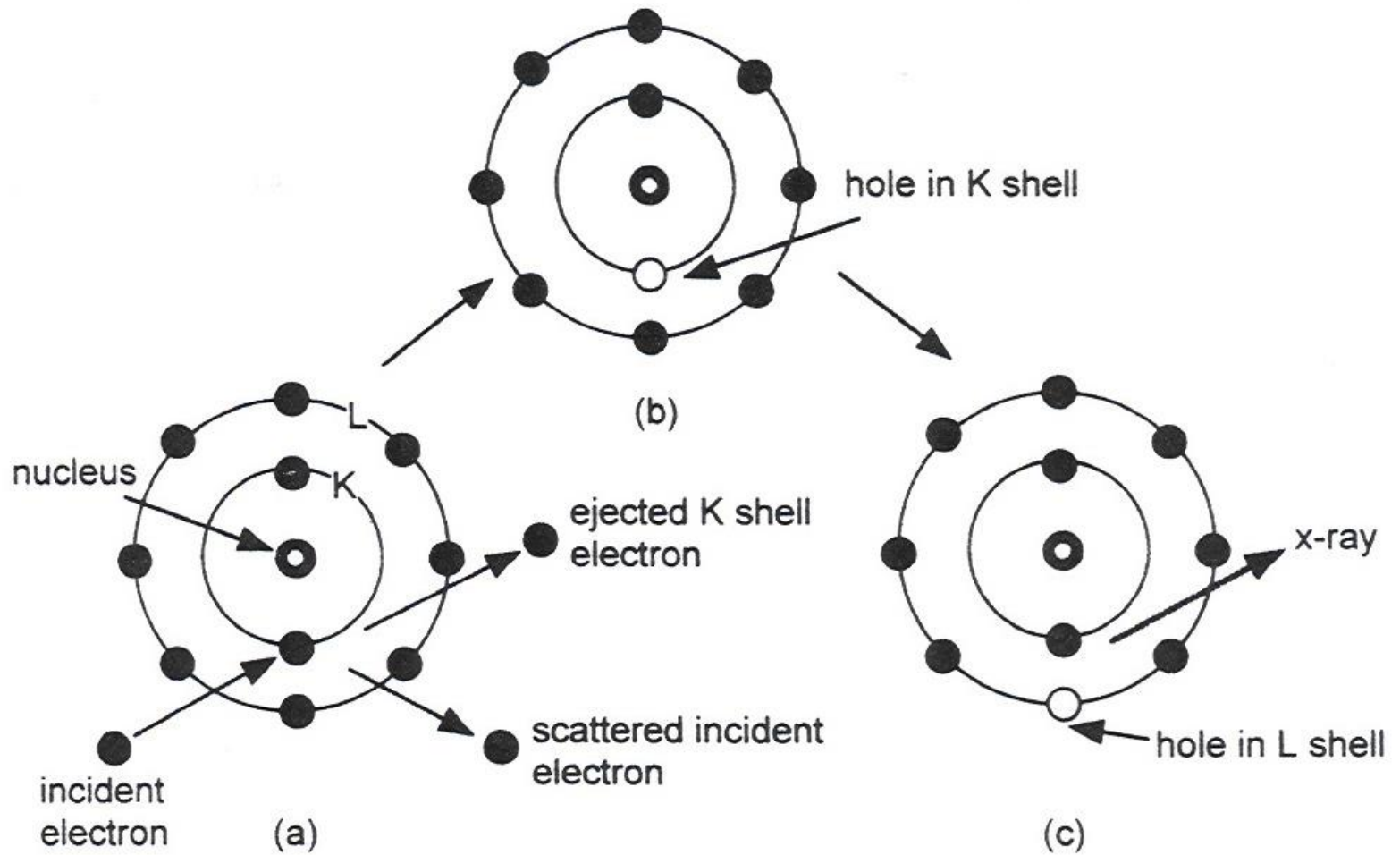
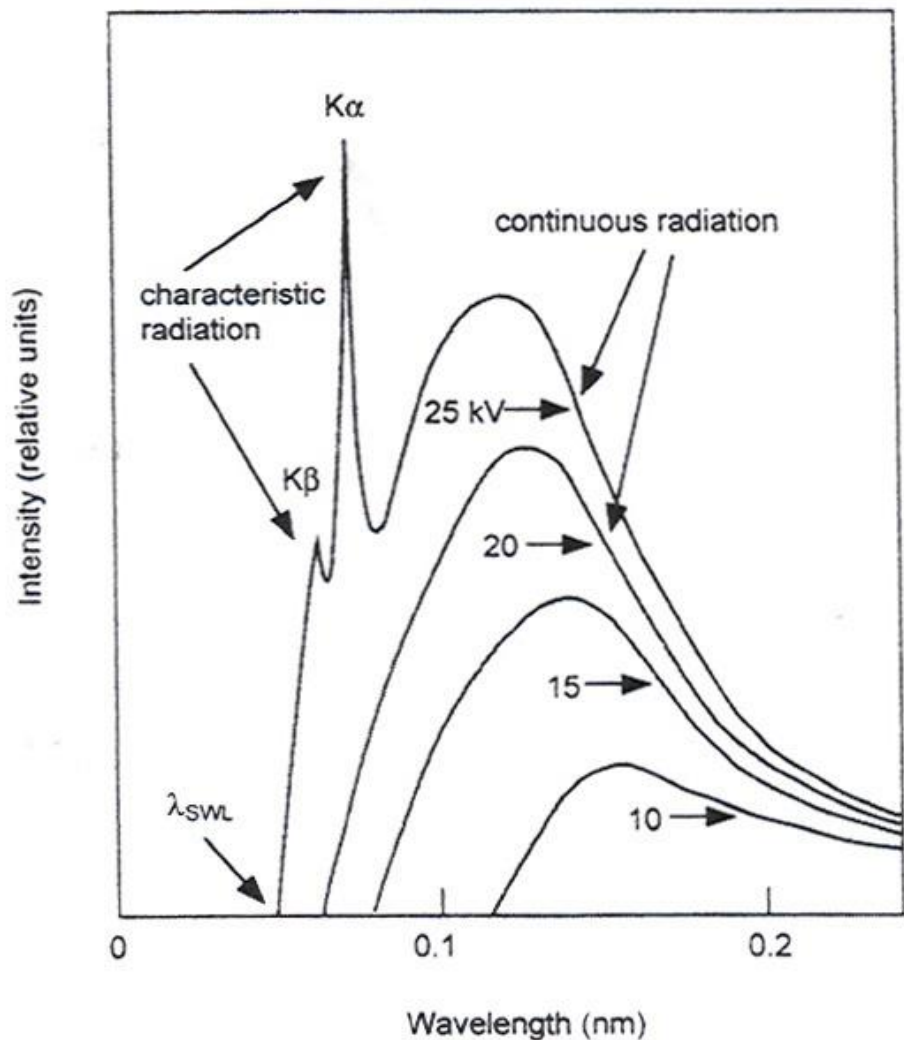

Illustration of the process of inner-shell ionization and the subsequent emission of a characteristic x-ray: (a) an incident electron ejects a K shell electron from an atom; (b) leaving a hole in the K shell; (c) electron rearrangement occurs, resulting in the emission of an x-ray photon.



X-ray spectrum of molybdenum at different potentials. The potentials refer to those applied between the anode and cathode. (The linewidths of the characteristic radiation are not to scale.) .

Production and Properties of X-rays

B. Properties of X-rays

2. Characteristic X-ray spectrum

These lines correspond to electron transfer between different energy levels and are classified as K, L, M, etc...

For Mo target, the K lines have a wavelength of $\sim 0.7 \text{ \AA}$, L lines = $\sim 5 \text{ \AA}$, etc... Normally the K lines are the most useful for x-ray diffraction.

Production and Properties of X-rays

B. Properties of X-rays

2. Characteristic X-ray spectrum

There are several K lines present, but the most useful are the strongest three, $K_{\alpha 1}$, $K_{\alpha 2}$, and K_{B1} .

For Mo the wavelength's of these lines are:

$$K_{\alpha 1} = 0.709\text{\AA} \quad K_{\alpha 2} = 0.714\text{\AA} \quad K_{B1} = 0.632\text{\AA}$$

the $\alpha 1$ and $\alpha 2$ components are very close and difficult to resolve except at higher angles.

$K_{\alpha 1}$ is 2 times as strong as $K_{\alpha 2}$

$K_{\alpha 1}$ is 5 times as strong as K_{B1}

Production and Properties of X-rays

B. Properties of X-rays

2. Characteristic X-ray spectrum

The voltage at which the characteristic spectrum occurs is called the critical voltage. Increases in the voltage, increase the intensity of the characteristic lines, but does not change their wavelengths.

Production and Properties of X-rays

B. Properties of X-rays

2. Characteristic X-ray spectrum

This intensity increase is given by:

$$I_{\text{K line}} = Bi(V - V_{\text{K}})^n$$

B - proportionality constant

i = tube current

V - applied voltage above the critical voltage of that line

V_K - K excitation voltage

Production and Properties of X-rays

B. Properties of X-rays

2. Characteristic X-ray spectrum

Intensities of these lines are much larger than for the adjacent wavelength.

Ex. $K\alpha$ of Cu is 90x as intense as the closest continuous wavelength.

Also these lines are extremely narrow $\sim 0.001\text{\AA}$ wide at half-max.

Production and Properties of X-rays

B. Properties of X-rays

2. Characteristic X-ray spectrum

Bragg discovered the characteristic lines.

H. G. Moseley systemized the lines

Moseley's law - the wavelength of any particular line decreases as the atomic number of the emitter increases. Linear relationship between the square root of the line frequency, ν , and the atomic number, Z .

$$\nu^{1/2} = C(Z - \sigma)$$

C and σ are constants

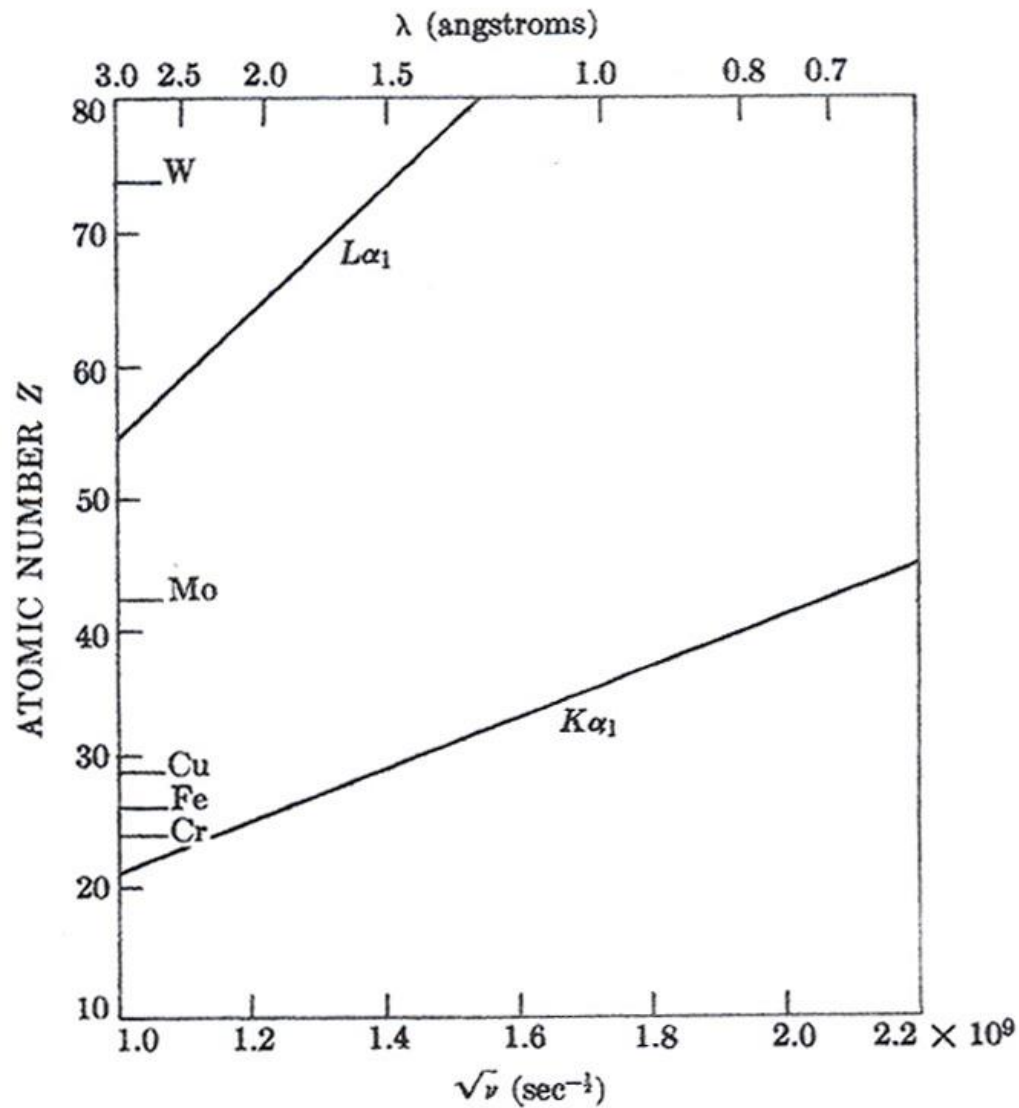

Moseley's relation between $\sqrt{\nu}$ and Z for two characteristic lines

Production and Properties of X-rays

B. Properties of X-rays

2. Characteristic X-ray spectrum

Characteristic lines correspond to electron transitions between different energy levels.

The final resting place of the electron determines the type of radiation.

There are also subshells, i.e. L consist of L_I , L_{II} , and L_{III} .

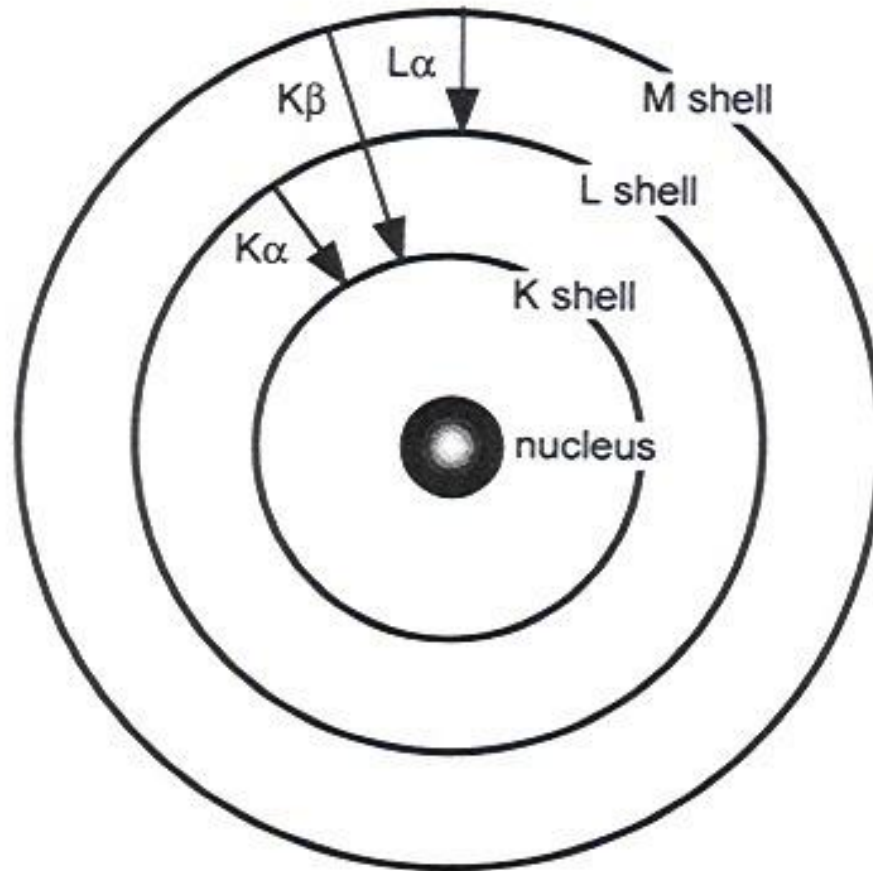

Electron transitions in an atom, which produce the $K\alpha$, $K\beta$ and $L\alpha$ characteristic x-rays.

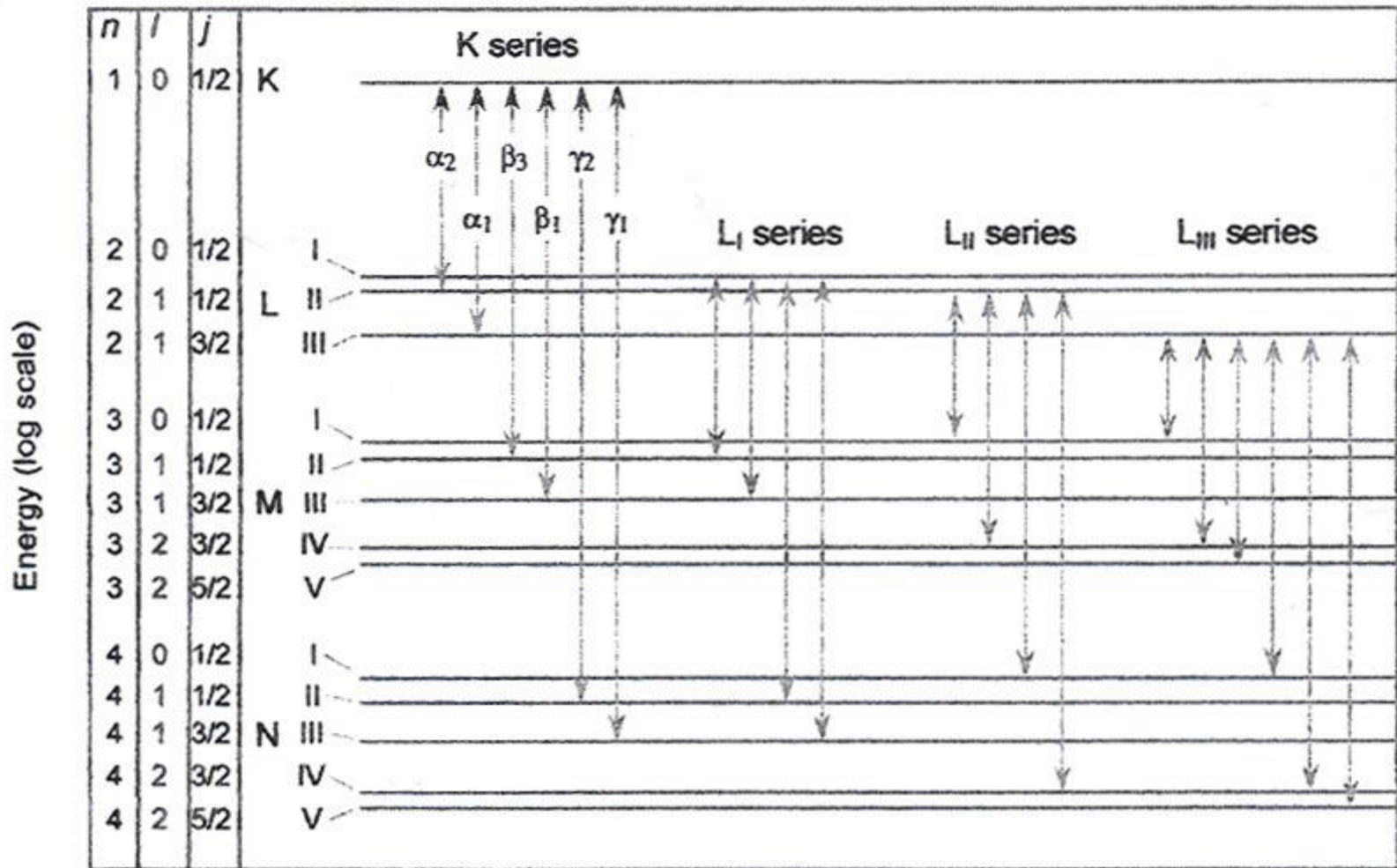

Energy-level diagram showing all the allowed electron transitions in a molybdenum atom.

Production and Properties of X-rays

B. Properties of X-rays

2. Characteristic X-ray spectrum

So the transition from L_{III} to $K = K_{\alpha 1}$ x-ray radiation and L_{II} to $K = K_{\alpha 2}$ x-ray radiation.

Example: For a Mo target

<u>Level</u>	<u>Energy (KeV)</u>
K	-20.00
L_{II}	-2.63
L_{III}	-2.52

For L_{III} to K transition for Mo $\Delta E = -20.00 - (-2.52) = -17.48$ KeV

$$\lambda = 12.40/17.48 \text{ KeV} = 0.709 \text{ \AA}$$

So, $K_{\alpha 1}$ for Mo = 0.709 \AA or 0.0709 nm

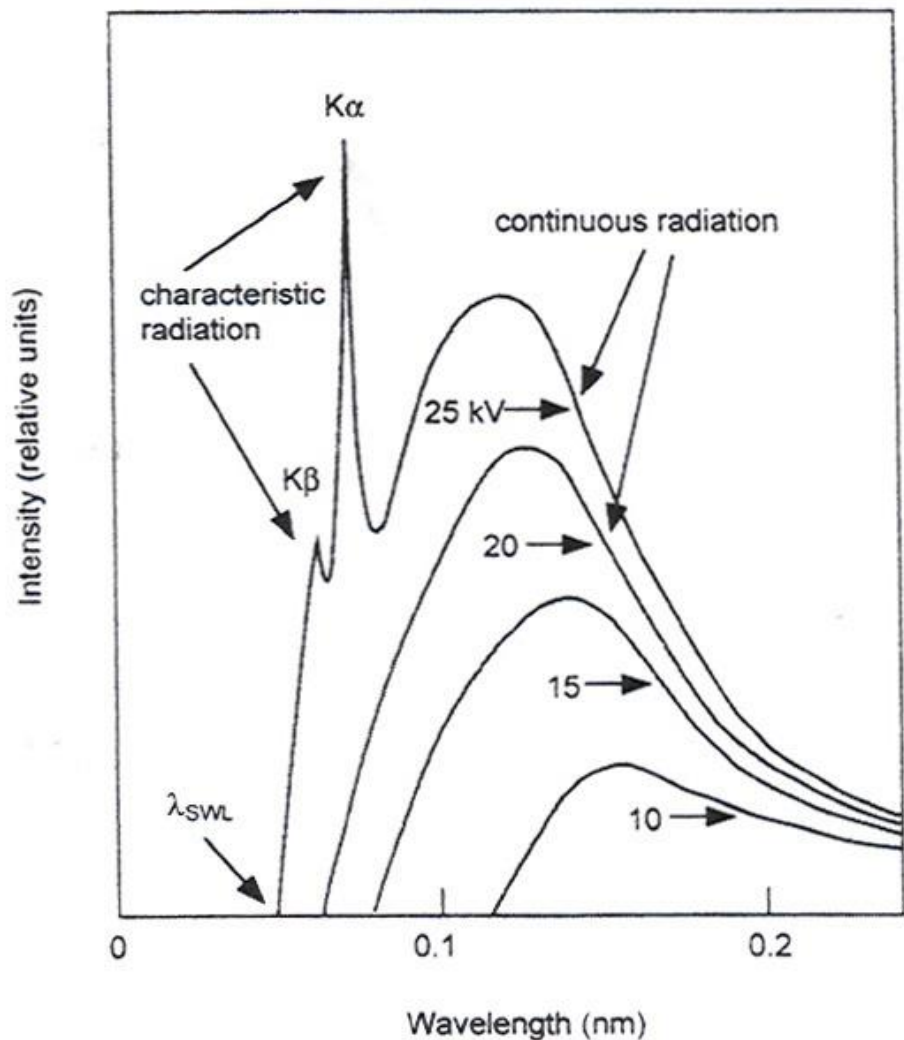

X-ray spectrum of molybdenum at different potentials. The potentials refer to those applied between the anode and cathode. (The linewidths of the characteristic radiation are not to scale.) .

Production and Properties of X-rays

Homework Assignment 1:

Calculate the λ for Cu $K_{\alpha 1}$, $K_{\alpha 2}$, and K_B , and memorize.

(Due next Tuesday)

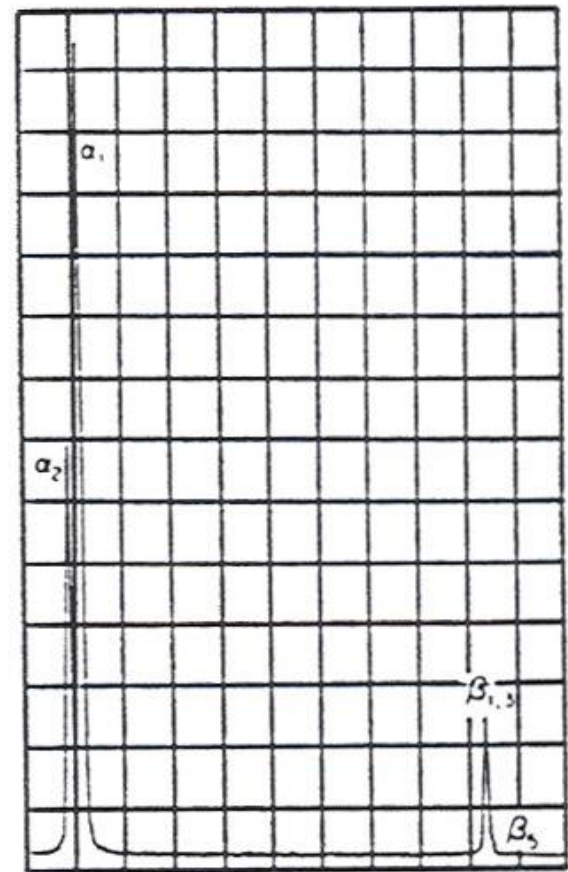
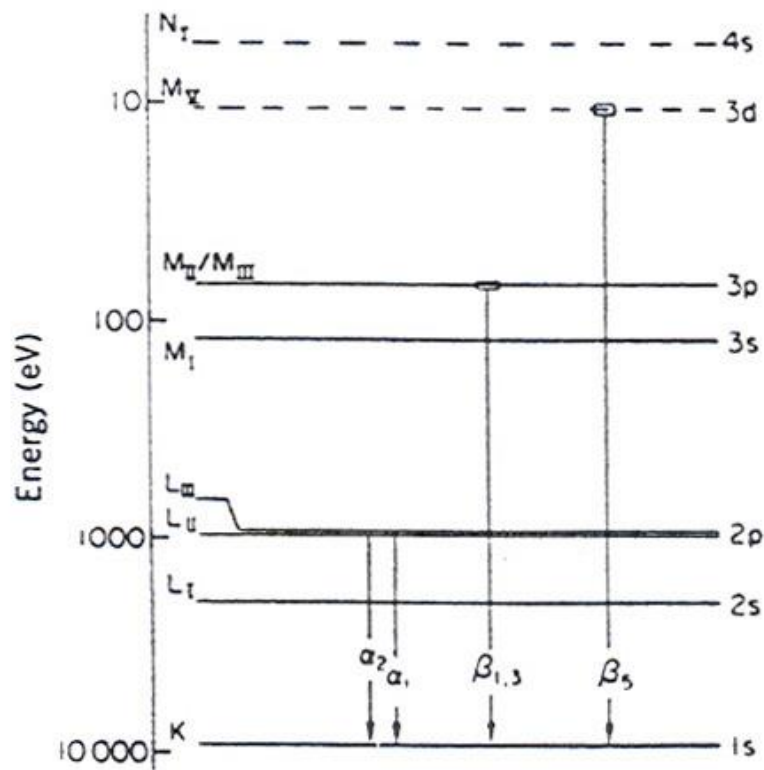
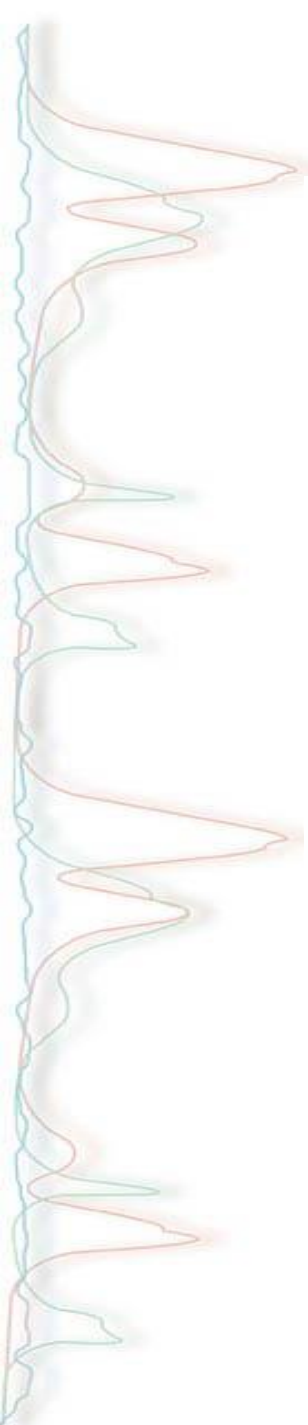

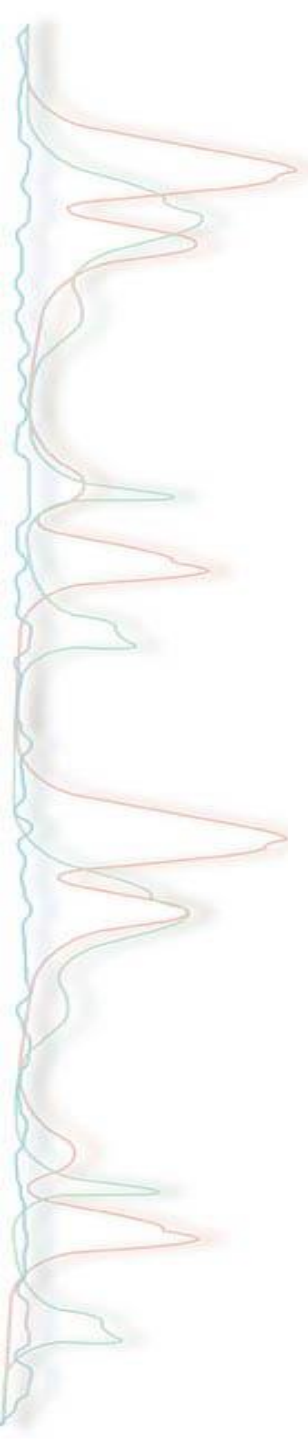

Level	Binding Energy (keV)
K	8.978
L_{II}	0.953
L_{III}	0.933
M_{II}	0.078
M_{III}	0.075



Assignment:

Read Chapter 1 from textbooks:

**-X-ray Diffraction, A Practical Approach
by Norton**

**-Elements of X-ray Diffraction by
Cullity and Stock**

**-Introduction to X-ray powder
Diffractometry by Jenkins and Synder**

Do Homework Assignment 1 – Due 9-3-24

