



# CHEMISTRY 4631

Instrumental Chemistry  
Lecture Signals and Noise



# Signals and Noise

**Instrumentation is used by chemist to solve analytical problems.**

- ▣ **Measurement of physical properties**
- ▣ **Identification of unknowns**
- ▣ **Preparation of components**

# Signals and Noise

**TABLE 1-1** Chemical and Physical Properties Employed in Instrumental Methods

<b>Characteristic Properties</b>	<b>Instrumental Methods</b>
Emission of radiation	Emission spectroscopy (X-ray, UV, visible, electron, Auger); fluorescence, phosphorescence, and luminescence (X-ray, UV, and visible)
Absorption of radiation	Spectrophotometry and photometry (X-ray, UV, visible, IR); photoacoustic spectroscopy; nuclear magnetic resonance and electron spin resonance spectroscopy
Scattering of radiation	Turbidimetry; nephelometry; Raman spectroscopy
Refraction of radiation	Refractometry; interferometry
Diffraction of radiation	X-Ray and electron diffraction methods
Rotation of radiation	Polarimetry; optical rotary dispersion; circular dichroism
Electrical potential	Potentiometry; chronopotentiometry
Electrical charge	Coulometry
Electrical current	Amperometry; polarography
Electrical resistance	Conductometry
Mass	Gravimetry (quartz crystal microbalance)
Mass-to-charge ratio	Mass spectrometry
Rate of reaction	Kinetic methods
Thermal characteristics	Thermal gravimetry and titrimetry; differential scanning calorimetry; differential thermal analyses; thermal conductometric methods
Radioactivity	Activation and isotope dilution methods

# Signals and Noise

All instruments have the same basic components:

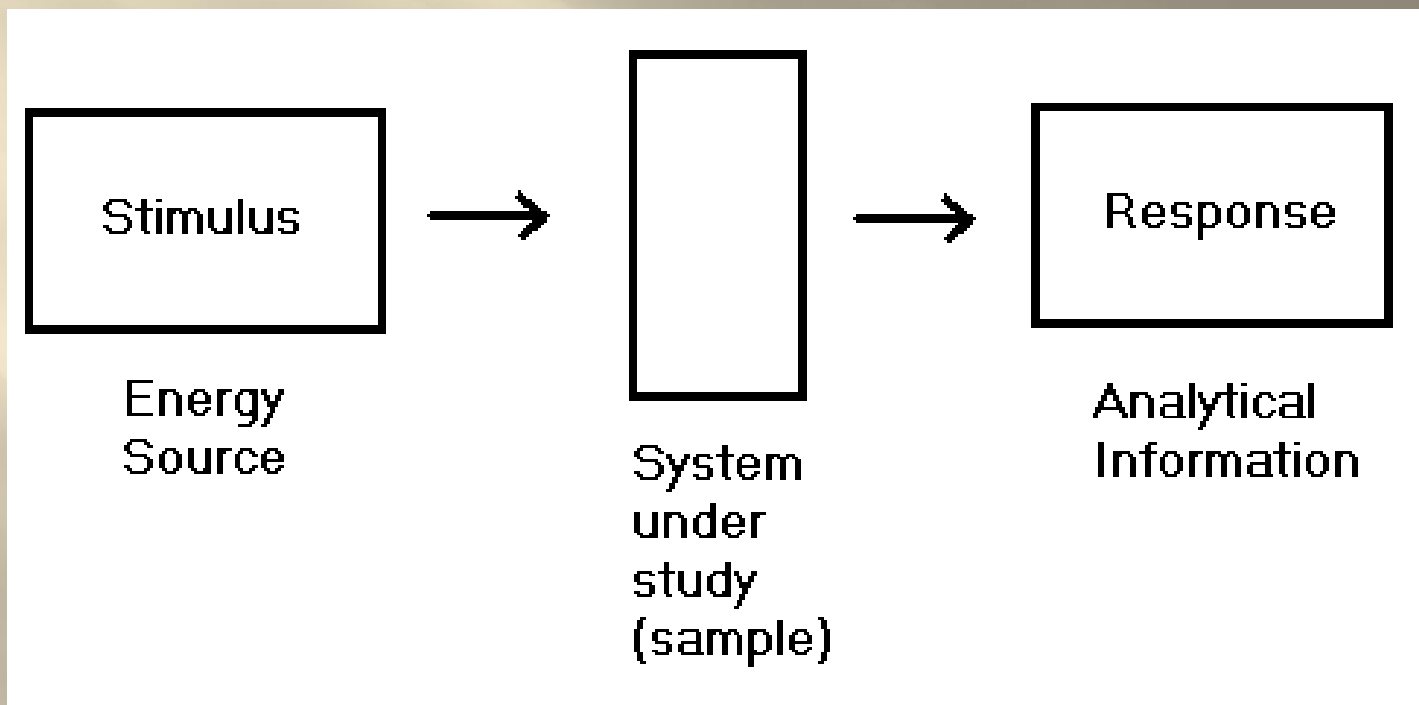

# Signals and Noise

**Source (Stimulus)**

**Must have enough energy to cause the desired transition.**

# Signals and Noise

**Detector (response or transducer)**

**The response is almost always represented by peaks,  
But can also be color or a number (i.e. temperature,  
pH, etc...)**

**Data can be represented in different types of  
domains:**

**Analog**

**Time**

**Digital**

# Signals and Noise

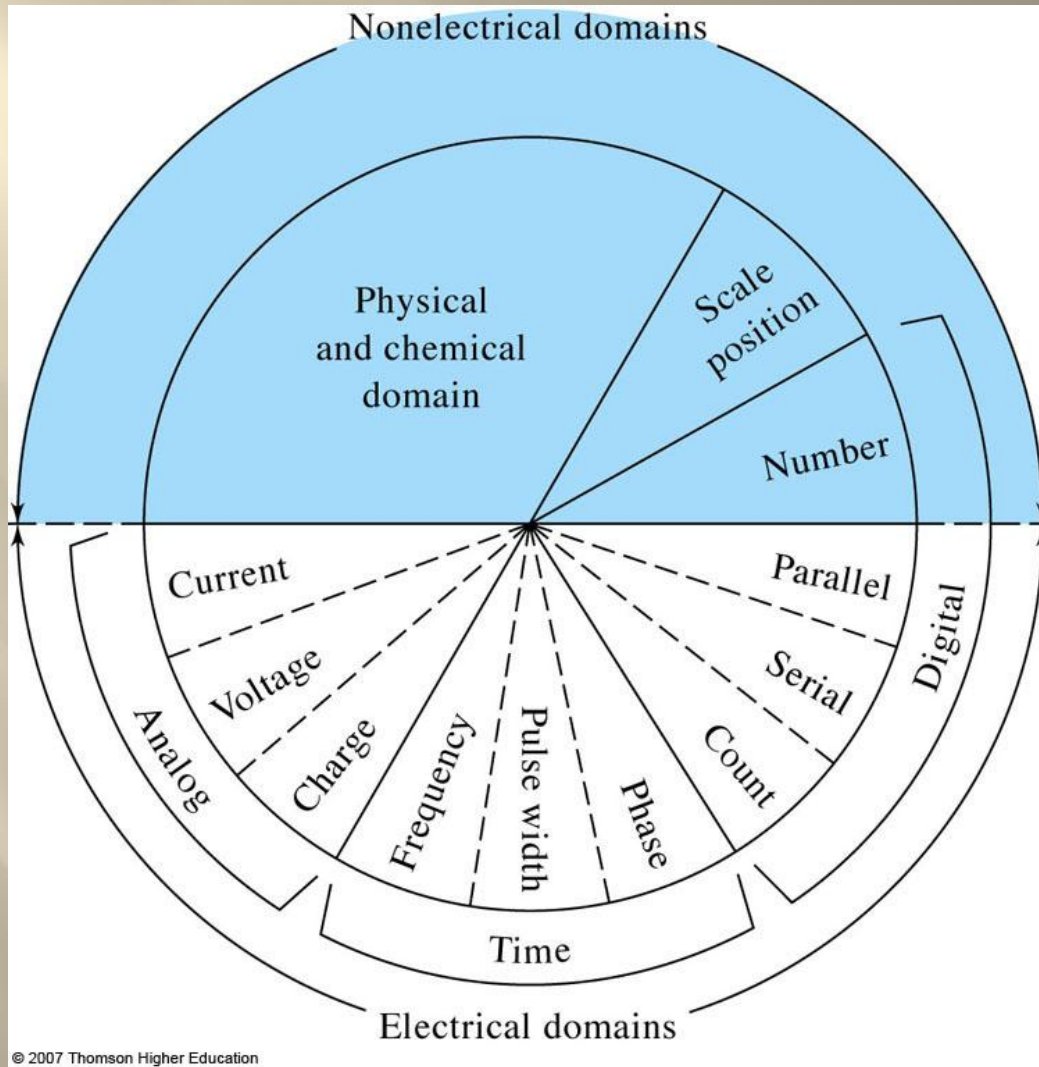

# Signals and Noise

## Analog Signals

Encoded as the magnitude of one of the electrical quantities:

Voltage, Current, Charge, or Power

# Signals and Noise

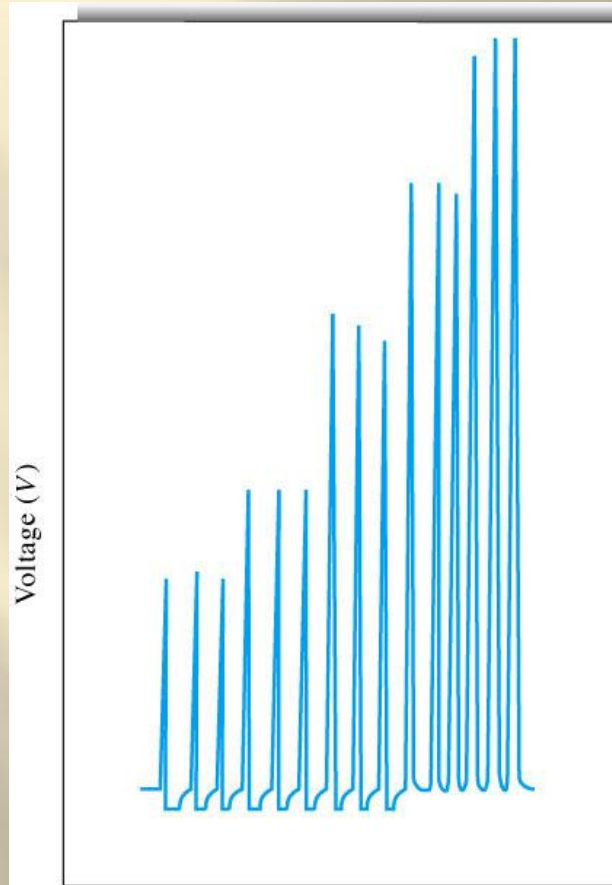

Time  
(a)

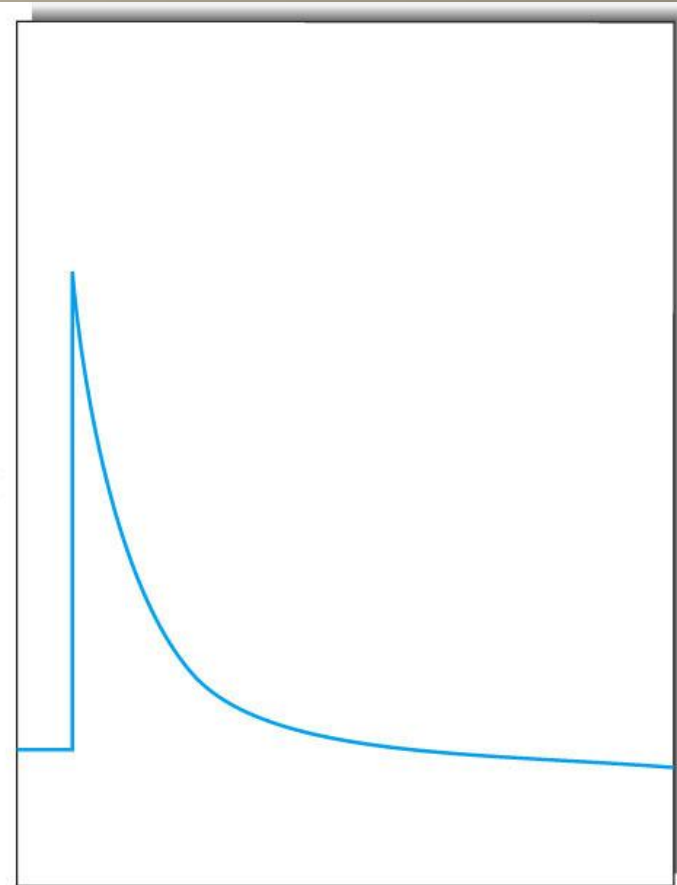

Time  
(b)

# Signals and Noise

## Time-Domain Signals

Information encoded as the time relationship of signal fluctuations. Frequency, period, pulse width.

# Signals and Noise

## Time-Domain Signals

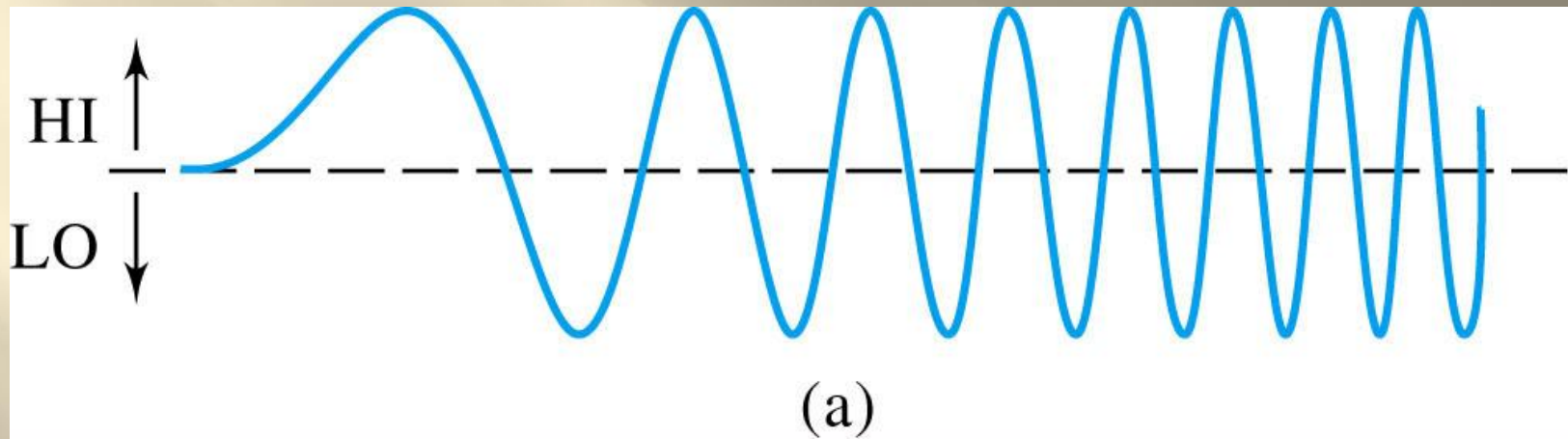

# Signals and Noise

## Digital Signals

Digital data is typically encoded in a two-level scheme. (On Off). Example: Logic level signal.

Each piece of data represents a bit (binary digit) of information.

# Signals and Noise

## Digital Signals

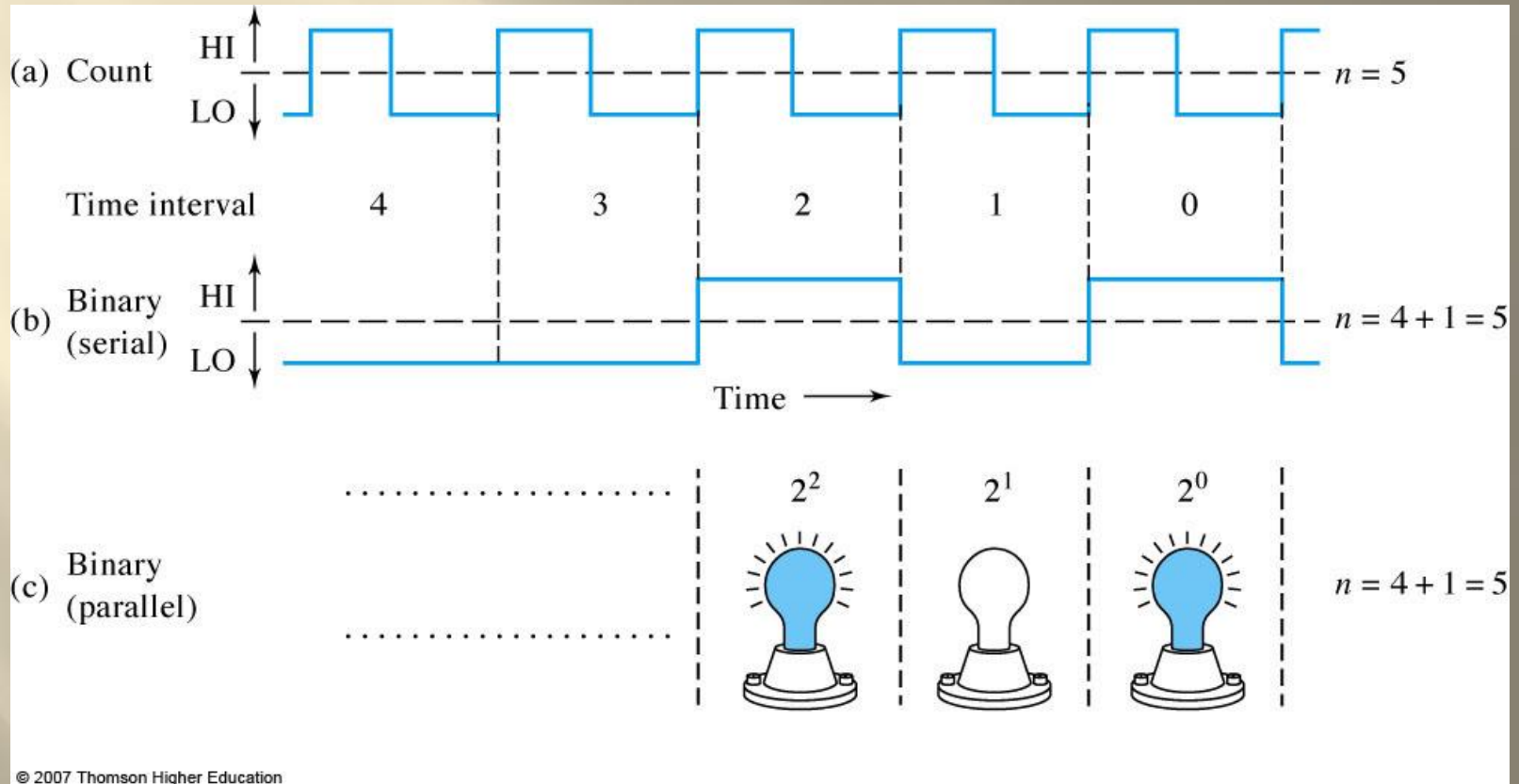

# Signals and Noise

Noise limits detectability of every instrumental method, cannot be completely removed.

Best we can do is understand contributions of noise and try to minimize noise.

- Enhance Signal
- Reduce Noise
- Modify Instrumental Method

Always trying to maximize the signal to noise ratio.

# Signals and Noise

Signal to noise (S/N) is given by:

$$\frac{S}{N} = \frac{\text{mean}}{\text{std.dev}} = \frac{\bar{x}}{s}$$

**x** - mean of the signal measurements

**s** - standard deviation of numerous measurements of the signal strength

# Signals and Noise

As a general rule, it is difficult to detect a signal when the signal-to-noise is less than 3.

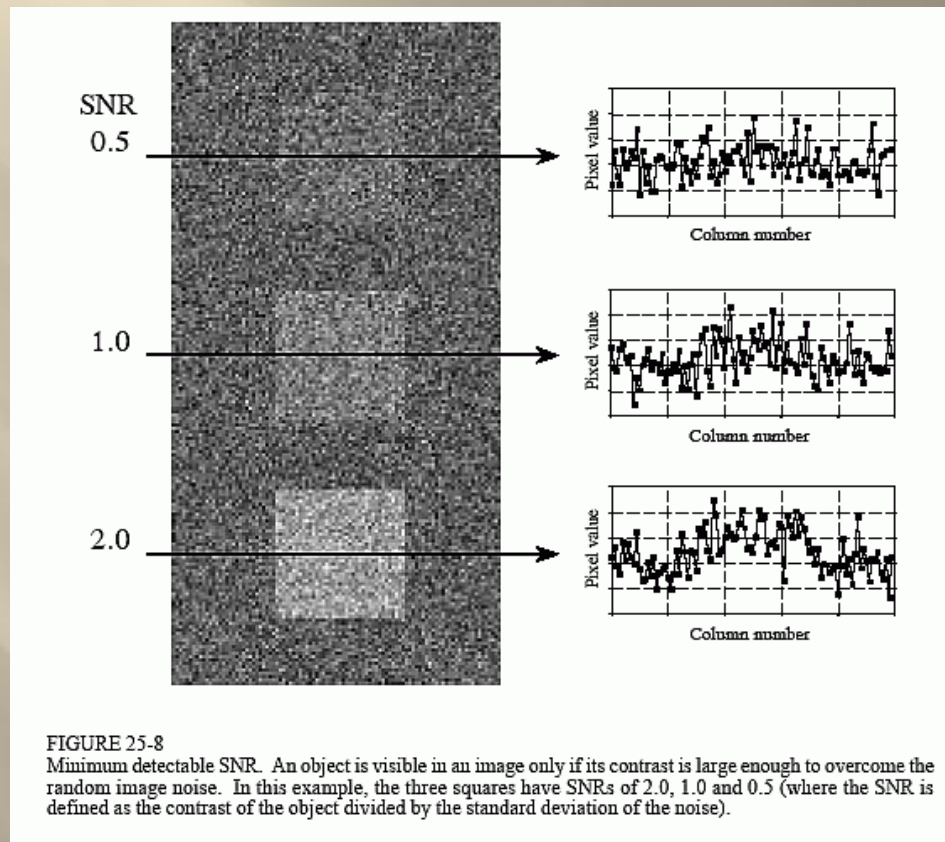

# Signals and Noise

**NMR spectra  
for  
Progesterone  
A)  $S/N = 4.3$   
B)  $S/N = 43$**

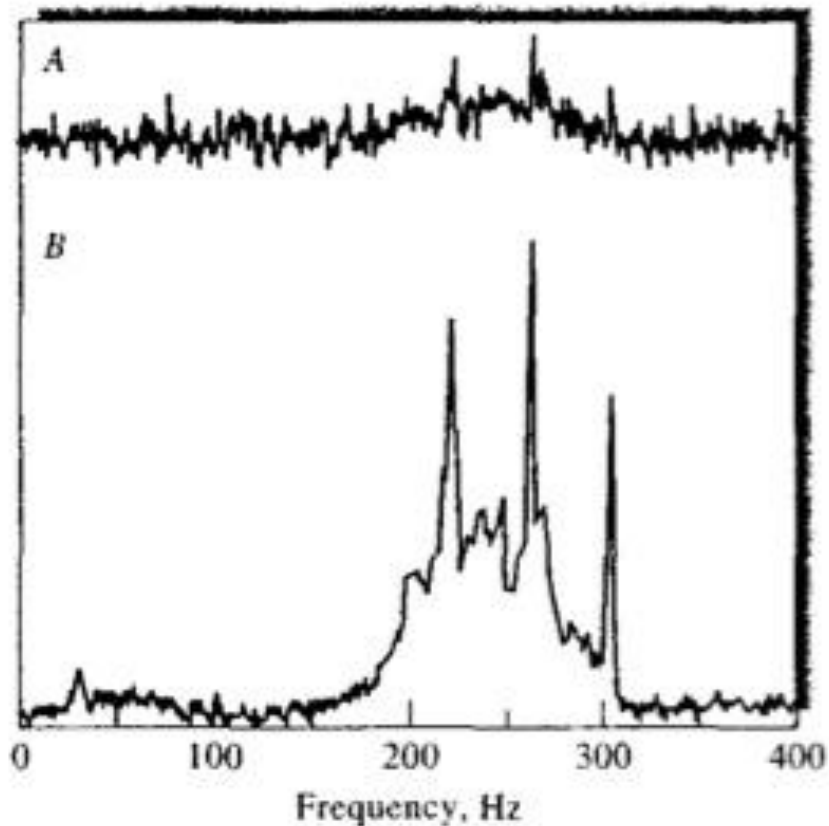

# Signals and Noise

## Sources of Noise

**Chemical noise – temp, pressure, humidity, vibrations, etc.**

**fluctuations = uncontrolled variables**

**Instrumental noise – noise from instrumental components.**

# Signals and Noise

**Instrumental noise – noise from instrumental components such as source, detector, electronic components.**

**Types of instrumental noise:**

- ▣ **Thermal or Johnson noise**
- ▣ **Shot noise**
- ▣ **Flicker or  $1/f$  noise**
- ▣ **Environmental noise**

# Signals and Noise

**Thermal noise (Johnson noise) – thermal motion of electrons or other carriers in resistors, capacitors, detectors, electrochemical cells, and other elements.**

**The agitation of charge carriers is random and can produce inhomogeneities setting up voltage fluctuations as noise.**

# Signals and Noise

Thermal noise is present even with no current present.

Magnitude of thermal noise:

$$\overline{V_{rms}} = \sqrt{4kTR\Delta f}$$

$V_{rms}$  - root mean square noise voltage

$k$  - Boltzman constant ( $1.38 \times 10^{-23}$  J/K)

$T$  - temperature

$R$  - resistance of the elements in ohms

$\Delta f$  - frequency bandwidth of the noise

# Signals and Noise

Thermal noise

$$\overline{U}_{rms} = \sqrt{4kTR\Delta f}$$

According to the equation, thermal noise can be decreased by:

- ❑ decreasing the temperature i.e. cooling detector with liquid nitrogen
- ❑ lowering the electrical resistance
- ❑ narrowing the bandwidth

# Signals and Noise

## Thermal noise

Problem with narrowing the bandwidth is that it affects the rise time,  $t_r$ , of the instrument.

$$\Delta f = \frac{1}{3t_r}$$

Rise time - response time in seconds to changes in input - measured as the time required for the output to increase from 10 to 90% of its final value.

As the bandwidth narrows, instrument response becomes slower to respond to signal change.

# Signals and Noise

**Shot noise – movement of electrons across a junction, i.e. at pn interfaces. Produces random currents.**

$$i_{rms} = \sqrt{2Ie\Delta f}$$

- ▣  $i_{rms}$  = root-mean square current fluctuation
- ▣  $I$  = average current
- ▣  $e$  = charge on electron ( $1.60 \times 10^{-19}$  C)
- ▣  $\Delta f$  = frequency bandwidth

# Signals and Noise

**Flicker or  $1/f$  noise** – any noise that is inversely proportional to the frequency of the signal.

**Cause is not well understood, but is significant at low frequency ( $<100$  Hz).**

**Seems to depend on the types of materials used and the shapes of devices.**

**Example – a resistor made of carbon has  $10\times$   $1/f$  noise as one made of metal.**

# Signals and Noise

**Flicker or  $1/f$  noise – any noise that is inversely proportional to the frequency of the signal.**

**Examples include long-term drift in dc amplifiers, light sources, voltmeters, etc.**

# Signals and Noise

**Environmental noise – composite of many noise sources in the surroundings.**

**Instruments carry electronics which act as antennas capable of picking up EM radiation and converting it to an electrical signal.**

**Sources of EM radiation: ac power lines, radio, tv, lights (ballasts for fluorescent lights convert the incoming power to an output frequency in excess of 20 kHz), etc.**

# Signals and Noise

## Environmental noise sources with frequency

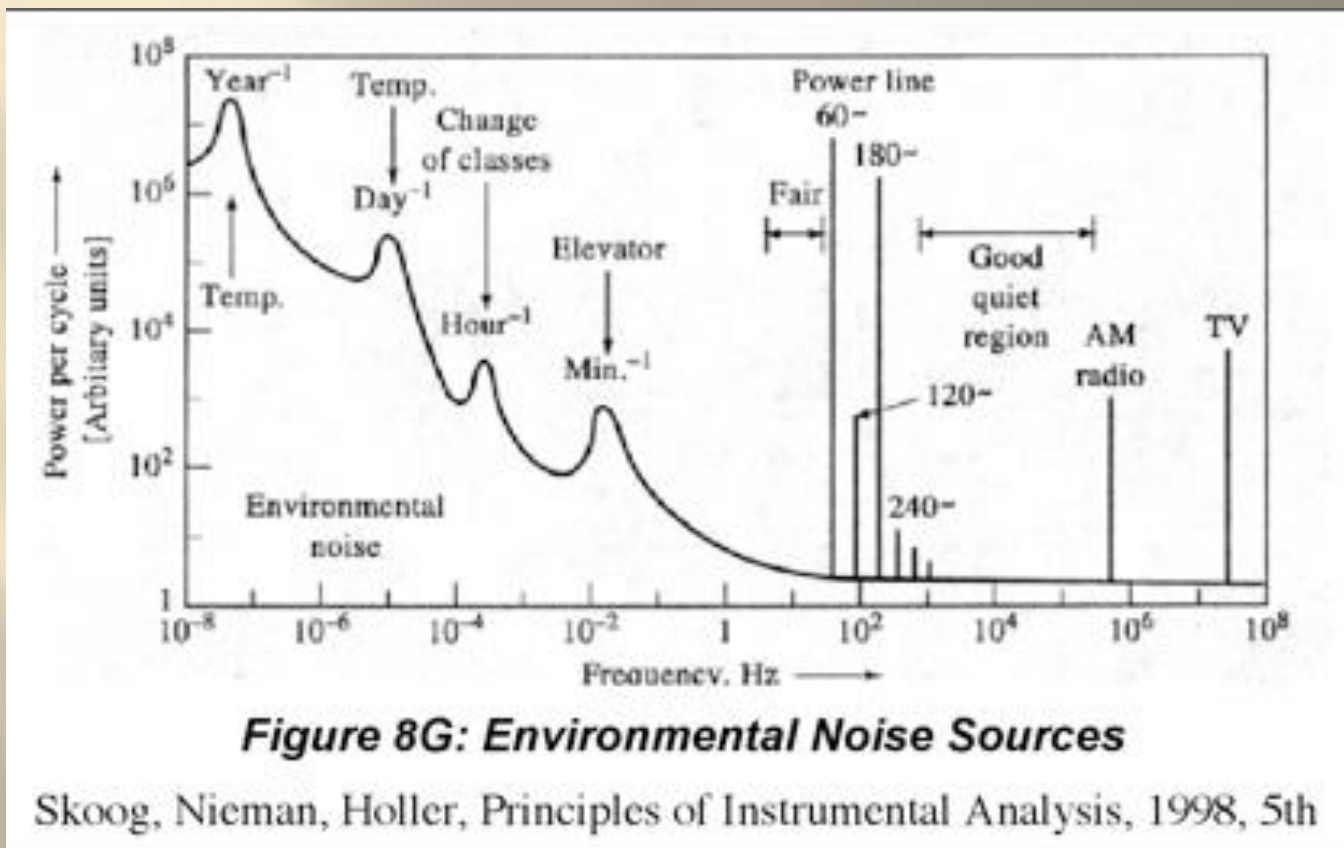

(note “good quiet region” - 20 kHz)

# Signals and Noise

## Effect of Instrumental Noise on Transmittance, $T$ , in Spectroscopy

### Instrumental Noise

#### Sources:

- $s_T = k_1$
- $s_T = k_2 (T^2 + T)^{1/2}$
- $s_T = k_3 T$

( $s_T$  - standard deviation of transmittance measurement)

# Signals and Noise

## Instrumental Noise

$$s_T = k_1$$

Encountered with less expensive equipment and readouts with limited resolution.

Also in IR equipment, due to Johnson noise (thermal noise) in the detector.

This creates voltage fluctuations.

# Signals and Noise

## Instrumental Noise

$$s_T = k_2 (T^2 + T)^{1/2}$$

Limits precision of high quality instruments.

Due to shot noise.

When electrons or charge particles cross a junction such as at pn interfaces or movement of electrons from a cathode to an anode in a PMT.

# Signals and Noise

## Instrumental Noise

$$s_T = k_3 T$$

From a slow drift in radiant output of the source called source flicker noise.

Minimized by good voltage power supplies or a split beam arrangement.

# Signals and Noise

**TABLE 13-3** Types and Sources of Uncertainties in Transmittance Measurements

Category	Characterized by <sup>a</sup>	Typical Sources	Likely To Be Important In
Case I	$s_T = k_1$	Limited readout resolution	Inexpensive photometers and spectrophotometers having small meters or digital displays
		Heat detector Johnson noise	IR and near-IR spectrophotometers and photometers
		Dark current and amplifier noise	Regions where source intensity and detector sensitivity are low
Case II	$s_T = k_2\sqrt{T^2 + T}$	Photon detector shot noise	High-quality UV-visible spectrophotometers
Case III	$s_T = k_3T$	Cell positioning uncertainties	High-quality UV-visible and IR spectrophotometers
		Source flicker	Inexpensive photometers and spectrophotometers

# Signals and Noise

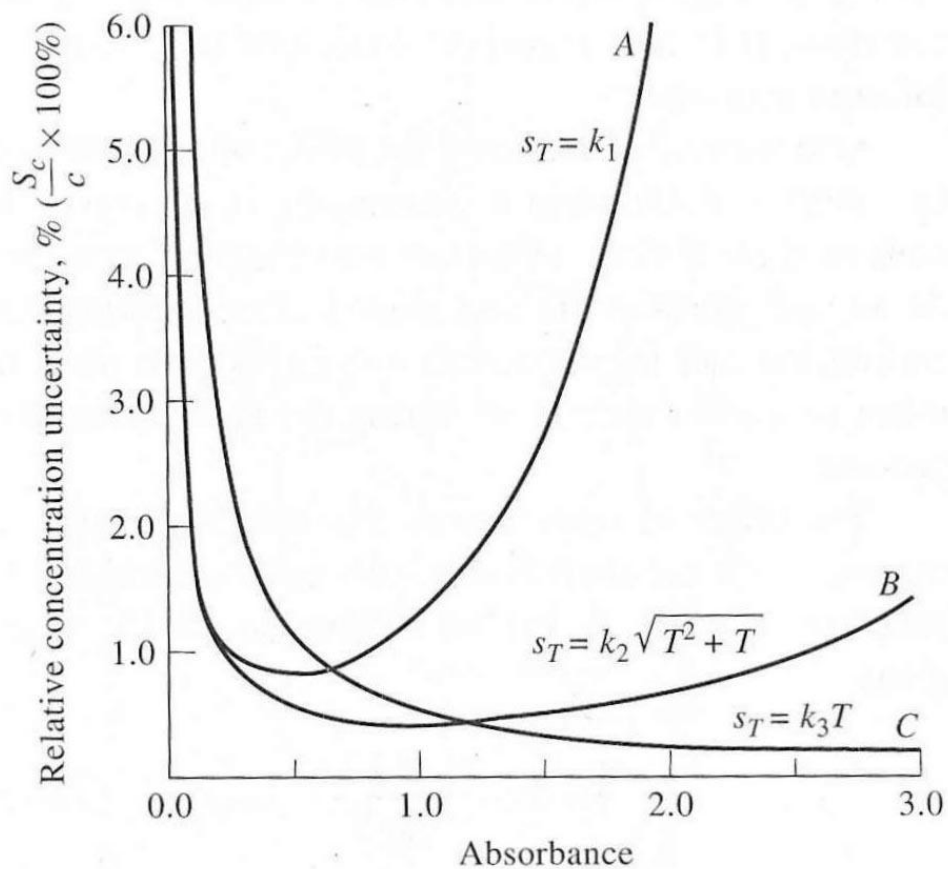

**Figure 13-7** Relative concentration uncertainties arising from various categories of instrumental noise: A, Case I; B, Case II; C, Case III. The data are taken from Table 13-4.

# Signals and Noise

## Improving S/N

- ❖ **Hardware – incorporate components into the instrument design, i.e. choppers, filters, etc.**
- ❖ **Software – use computer algorithms to extract signals from noise.**

# Signals and Noise

## Improving S/N

### Hardware

- ▣ Grounding & shielding
- ▣ Difference and instrumentation amplifiers
- ▣ Analog filtering
- ▣ Modulation
- ▣ Signal chopping
- ▣ Lock-in amplifiers

# Signals and Noise

## Hardware

- ▣ **Grounding & shielding**
  - Noise from environmental sources can be minimized by shielding, controlling lead lengths and grounding.

**Shielding** - consists of surrounding the electronics with a conducting material connected to earth ground.

# Signals and Noise

Faraday  
Cage



# Signals and Noise

**The effectiveness of the shield is dependent on:**

- **Thickness - the thinner the shield the less effective. This is particularly true of low-frequency noise.**

**Aluminum foil shield works well at rejecting up to 90 dB at frequencies above 30 MHz, but it's inadequate at fending off low-frequency magnetic fields (it's practically transparent below 1 kHz).**

# Signals and Noise

**The effectiveness of the shield is dependent on:**

- ❑ **Conductivity** - the shield must be able to sink all stray currents to the ground plane more easily than anything else.
- ❑ **Continuity** - cannot break the shield. It must be continuous around the signal paths, otherwise the noise will leak in like water into a hole in a boat.

**Most high-frequency noise problems are caused by openings in the shield material.**

# Signals and Noise

## Improving S/N

### Hardware

- ▣ **Analog filtering - RC filtering**  
Common method to improve S/N by using low-pass analog filters.  
Remove high frequency components of the signal such as thermal and shot noise.

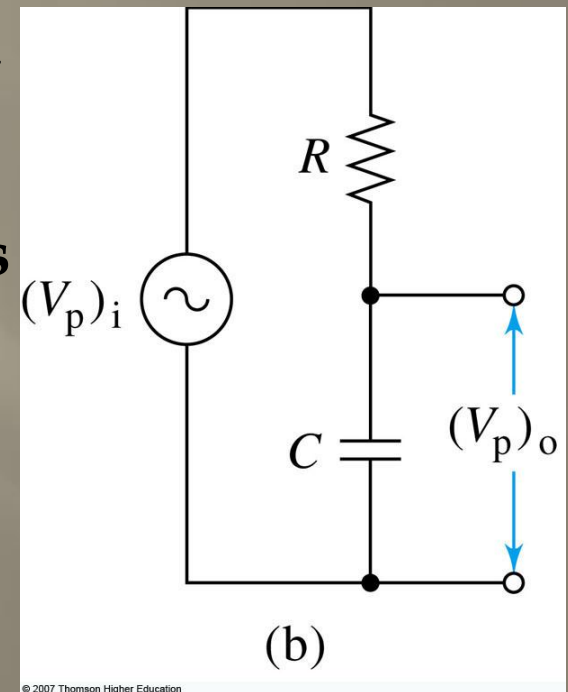

# Signals and Noise

## Analog Filtering or RC Filtering

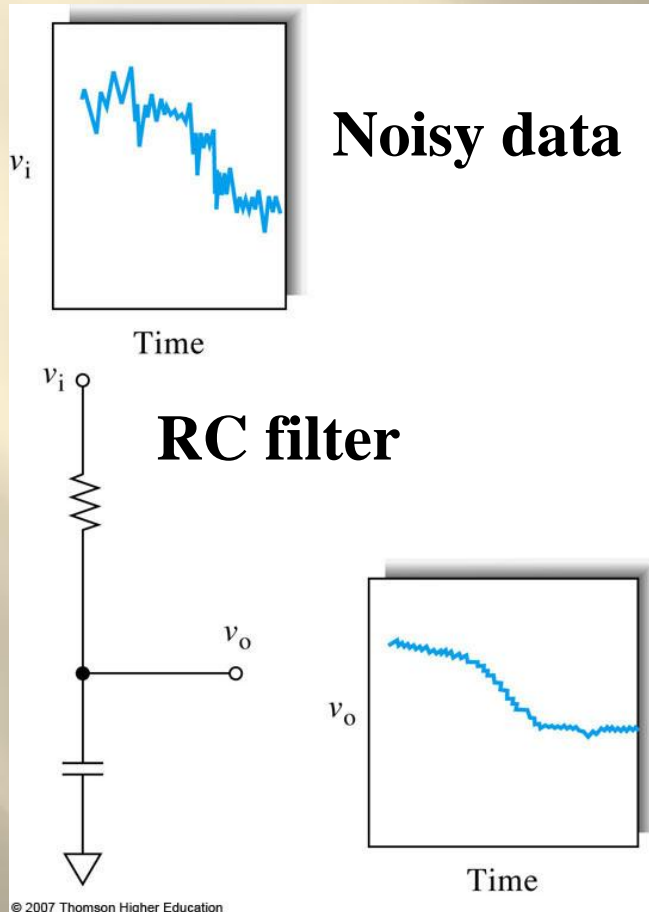

Example of using low pass filter for noise.

Filtered data

# Signals and Noise

## Improving S/N

### Hardware

- ▣ Analog filtering - RC filtering  
High pass filters used for high frequency signals to reduce drift and flicker noise.

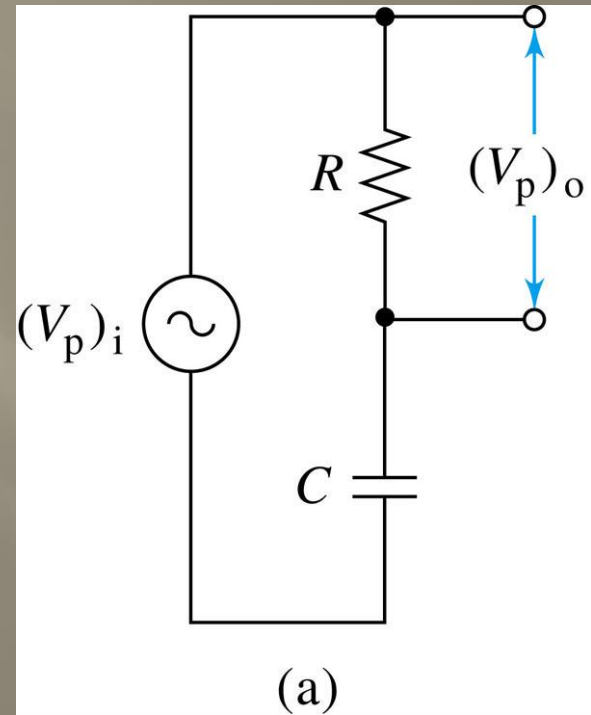

# Signals and Noise

## Improving S/N

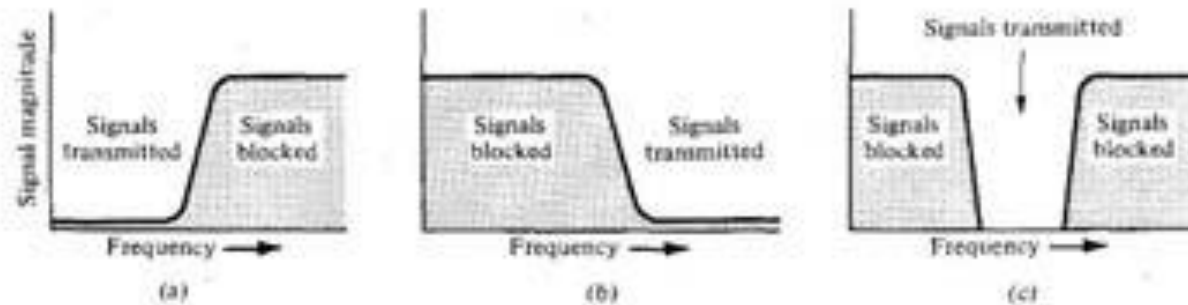

**FIGURE 2.6**  
Passive filters: (a) low-pass RC filter, (b) high-pass LC filter, and (c) low-pass LR filter.

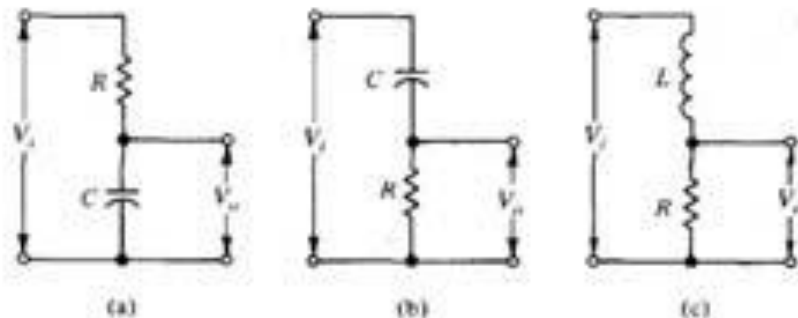

# Signals and Noise

## Improving S/N

### Hardware

- ▣ Modulation - convert low frequencies or dc signals from detector to high frequency ac.

Use modulation when a low frequency or dc detector signal needs to be amplified - since this is also the region where instruments have amplifier drift and flicker noise.

# Signals and Noise

**Improving S/N**

**Hardware**

**Modulation**

**When the signal is modulated, the  $1/f$  and power line noise can then be removed with a high-pass filter leaving the filtered signal to be demodulated and amplified.**



# Signals and Noise

**Improving S/N**

**Hardware**

**Modulation can be accomplished by using mechanical devices, such as choppers  
electrical circuits, such as lock-in amplifiers.**

# Signals and Noise

## Signal chopping in spectroscopy

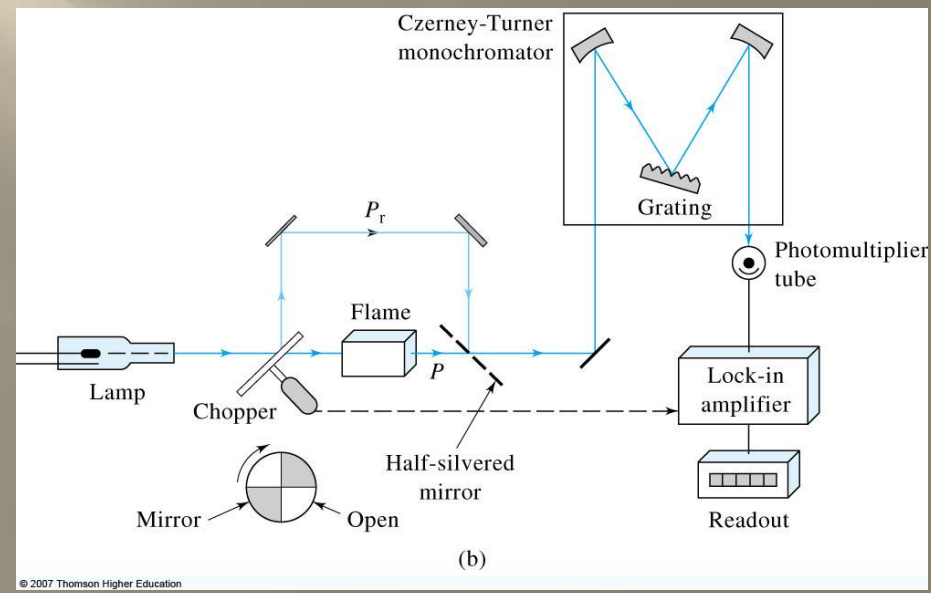
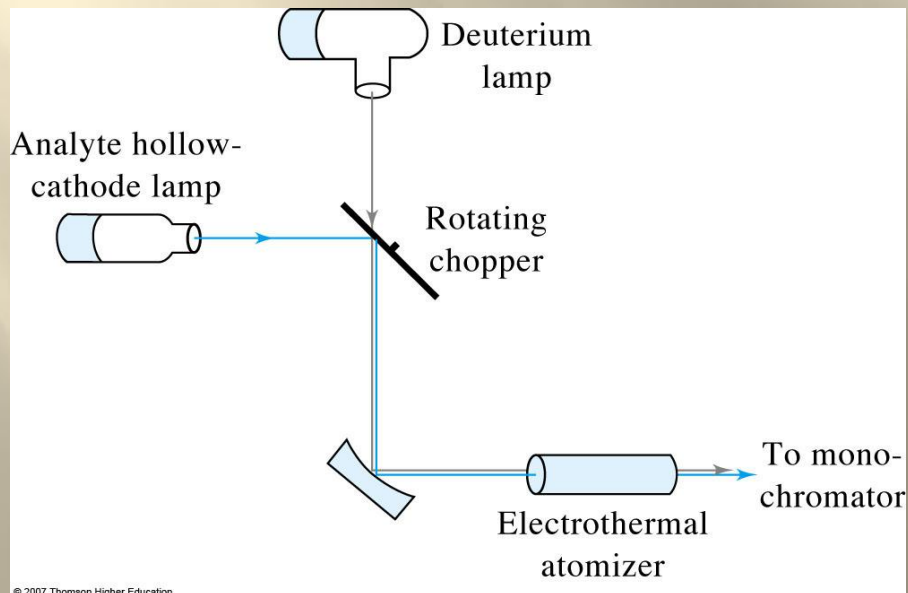
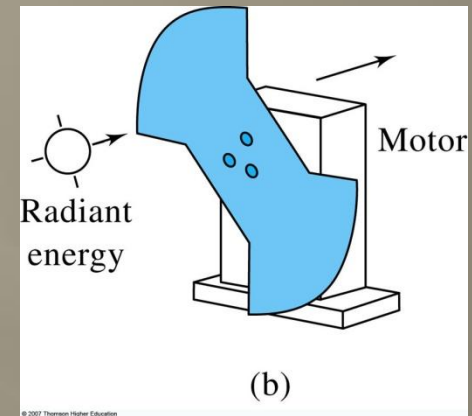

# Signals and Noise

## Improving S/N

### Software

- ▣ Ensemble averaging
- ▣ Boxcar averaging
- ▣ Digital filtering
- ▣ Correlation methods

# Signals and Noise

## Improving S/N

### Software

- ▣ Ensemble averaging – adding spectra

Each data set is stored and summed point by point for averaging.

Important to sample at twice the frequency or higher than the highest frequency component of the waveform. (Nyquist sampling theorem)

NMR and FTIR can use this method.

# Signals and Noise

Ensemble averaging  
of an NMR signal

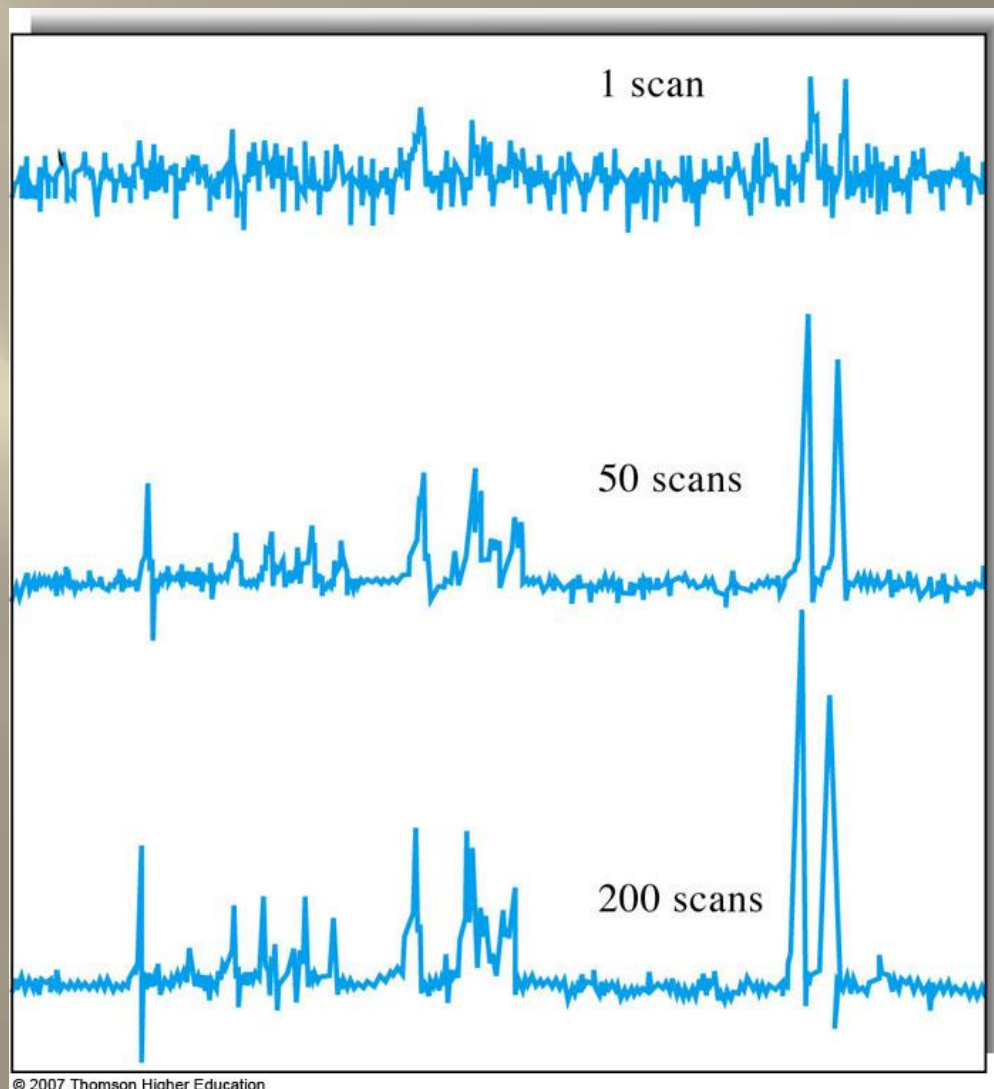

# Signals and Noise

## Improving S/N

### Software

- ▣ **Boxcar averaging - helps smooth peaks and enhance S/N in the waveform.**
  - Typically average 2-50 adjacent points to generate the final point.

**Not a good technique for complex signals or signals that change rapidly with time.**

# Signals and Noise

## Boxcar averaging

The effect of Boxcar averaging (a) Original Data (b) Data after Boxcar averaging (c) Data after moving-window boxcar averaging.

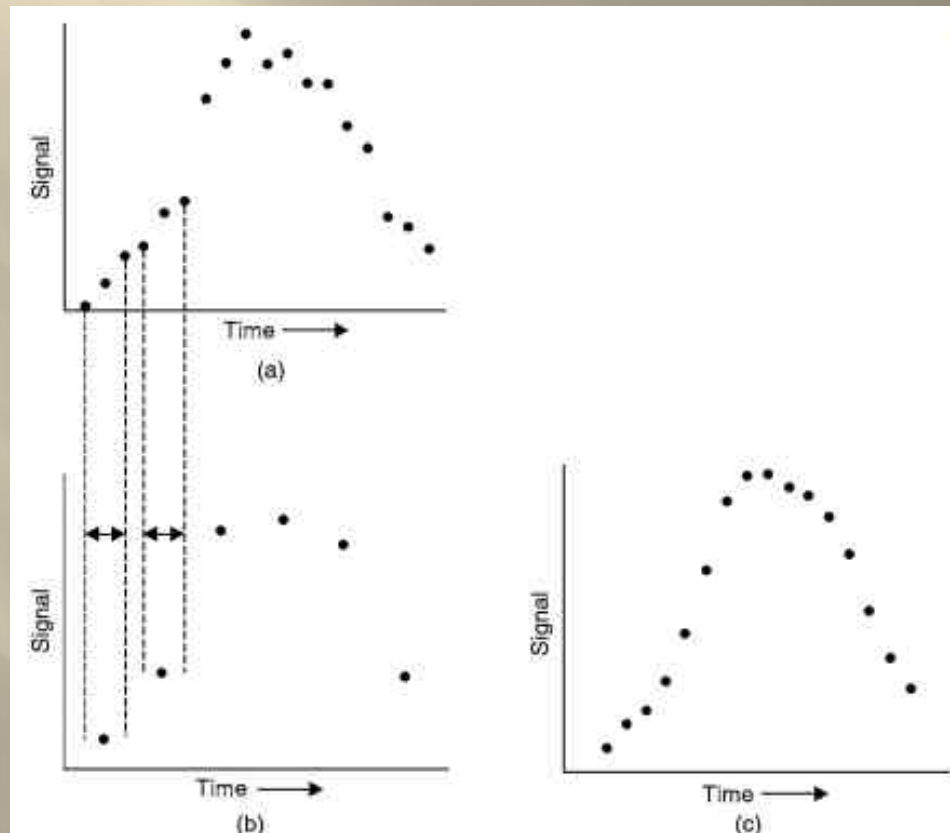

# Signals and Noise

**Improving S/N**

**Software**

- ▣ **Digital filtering - fourier transformation, least squares polynomial smoothing (moving window or sliding average), and correlation.**

# Signals and Noise

## Smoothing

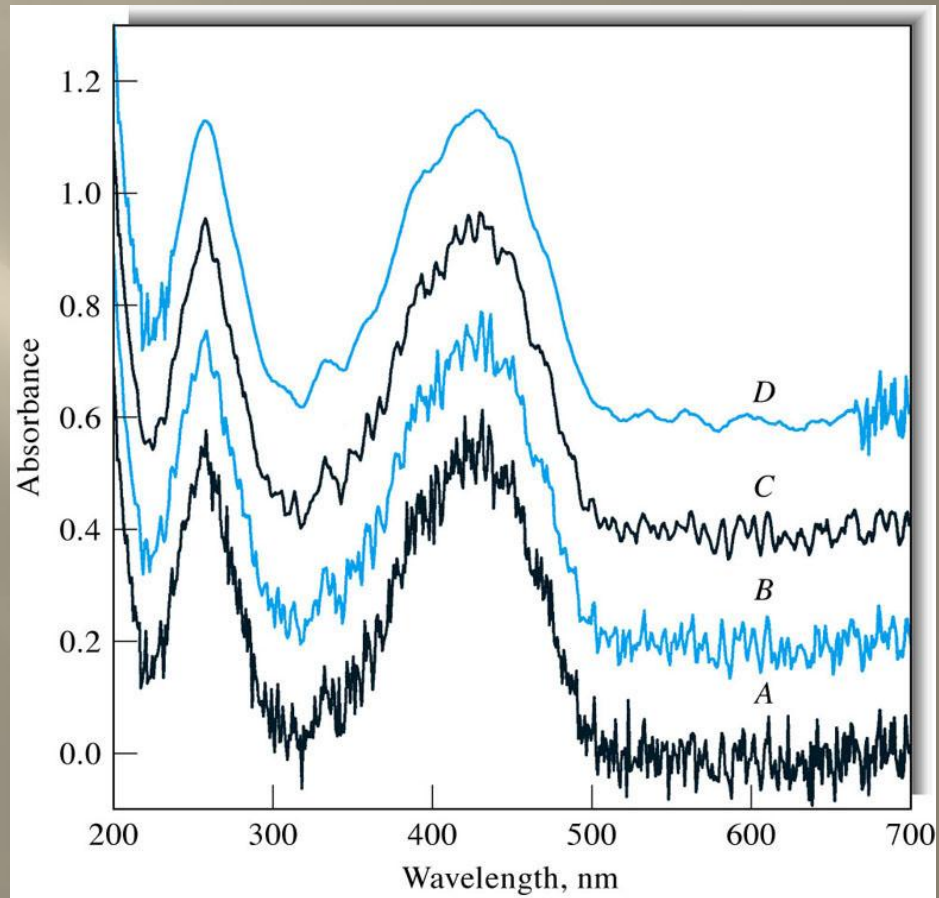
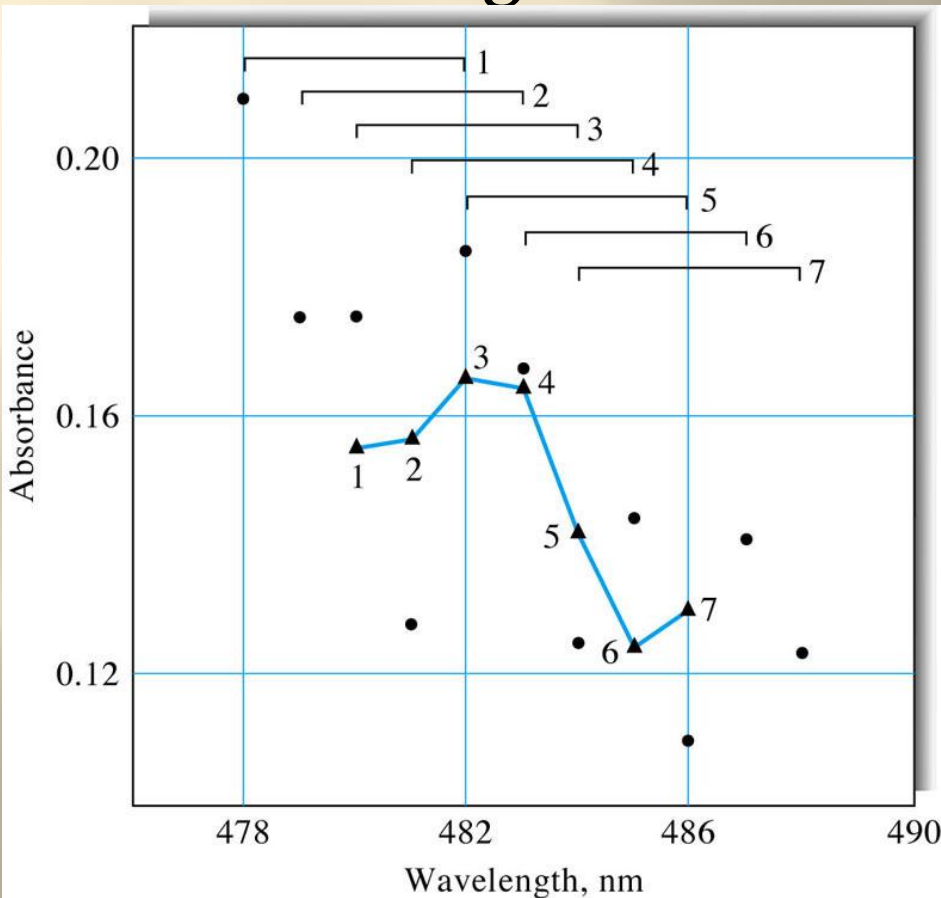

# Assignments

Signals and Noise in Instrumentation